

# PYPLOK<sup>®</sup> Tooling

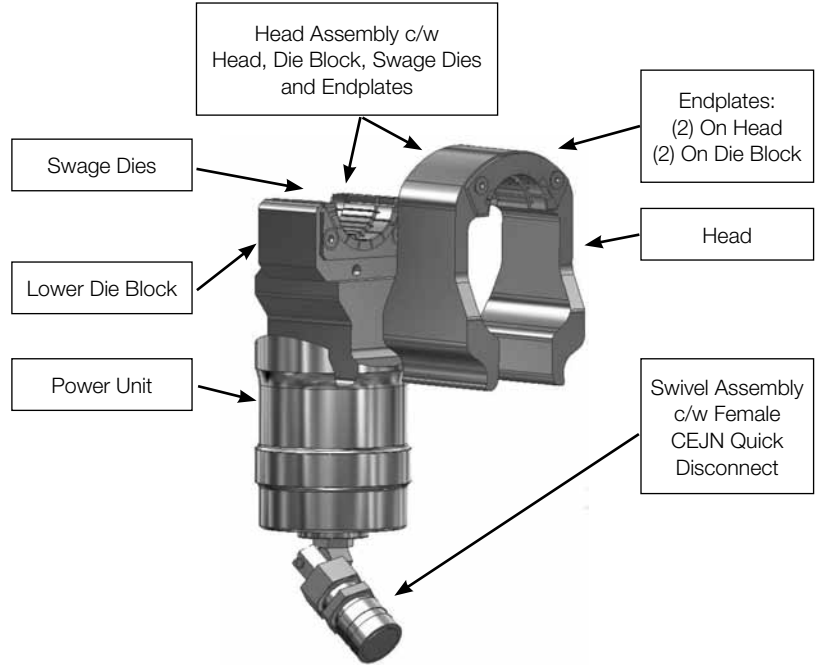

## Tooling Dimensions

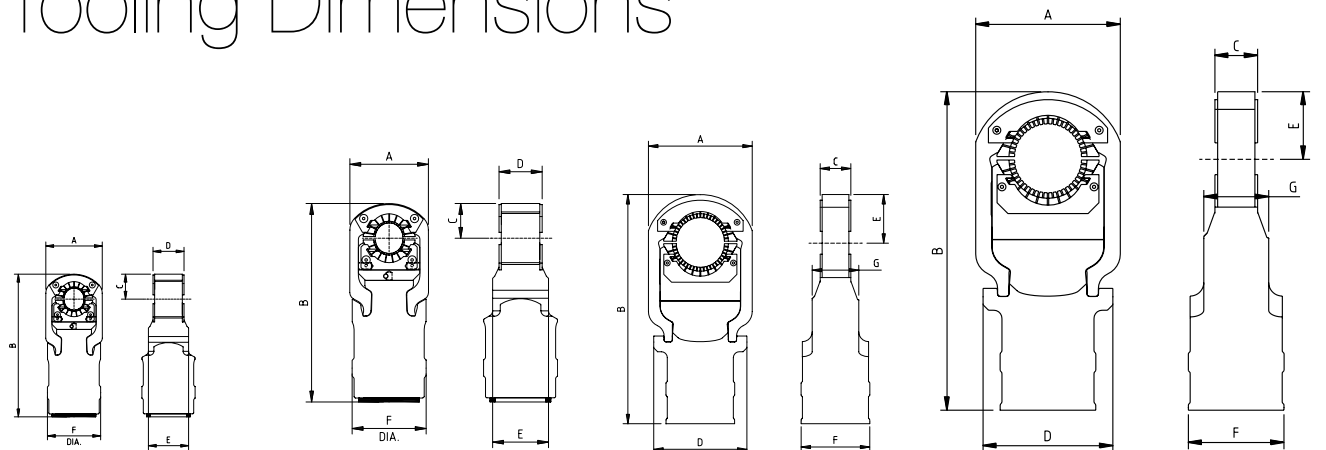

**MODEL 10**

	Head Series
	<b>01</b>
A	34
B	11
C	16
D	24
E	33
F	41

**MODEL 40**

	Head Series	
	<b>00</b>	<b>02</b>
A	84	89
B	214	224
C	35	141
D	34	49
E	64	63
F	84	84

**MODEL 55**

	Head Series
	<b>01</b>
A	132
B	252
C	49
D	152
E	94
F	105
G	76

**MODEL 70**

	Head Series	
	<b>01</b>	<b>02</b>
A	170	192
B	372	386
C	43	51
D	150	150
E	77	77
F	112	112
G	76	76

ALL DIMENSIONS IN MM

SEE PAGES 22 - 25 FOR CORRECT HEAD SERIES SELECTION.

# NB PIPE – DM 20 / DP 40 SERIES – TOOL PARTS MATRIX (NEW GENERATION TOOL)

\*Head Assembly Includes: Die Set, Die Block, Head, Endplates and Endplate Bolts

## MODEL 40 POWER UNIT – DLT40MAPW0000

Size	Fitting Series	Inspection Gauge	Die Set	Die Block	Head	Upper Endplates	Lower Endplates	Endplate Bolts	Head Assembly*
<b>MODEL 40 - 00' SERIES</b>									
1/4"	DM 20 Series NB Pipe	DLT40PYIG3804	DLT40PYD13804	DLT40MADA0000	DLT40MAHD0000	DLT40PYEU0000	DLT40PYEL0000	MS51595-61 10-24 x 3/8" Flat Socket Cap	DLT40PYHA3804
3/8"		DLT40PYIG3806	DLT40PYD13806						DLT40PYHA3806
<b>MODEL 40 - 02' SERIES</b>									
1/2"	DM 20 Series NB Pipe	DLT40PYIG3808	DLT40PYD13808	DLT40MADA0002	DLT40MAHD0002	DLT40PYEU0002	DLT40PYEL0002	MS51595-61 10-24 x 3/8" Flat Socket Cap	DLT40PYHA3808
3/4"		DLT40PYIG3812	DLT40PYD13812						DLT40PYHA3812

## MODEL 55 POWER UNIT - DLT55MAPW0000

Size	Fitting Series	Inspection Gauge	Die Set	Die Block	Head	Upper Endplates	Lower Endplates	Endplate Bolts	Head Assembly*
<b>MODEL 40 - 00' SERIES</b>									
1/2"		DLT40PYIG3808	DLT55PYD13808						DLT55PYHA3808
3/4"		DLT40PYIG3812	DLT55PYD13812						DLT55PYHA3812
1"	DM 20 Series NB Pipe	DLT55PYIG3816	DLT55PYD13816	DLT55MADA0001	DLT55MAHD0001	DLT55PYEU0001	DLT55PYEL0001	MS51595-61 10-24 x 3/8" Flat Socket Cap	DLT55PYHA3816
1-1/4"		DLT55PYIG3820	DLT55PYD13820						DLT55PYHA3820
1-1/2"		DLT55PYIG3824	DLT55PYD13824						DLT55PYHA3824

## MODEL 70 POWER UNIT - DLT70MAPW0000

Size	Fitting Series	Inspection Gauge	Die Set	Die Block	Head	Upper Endplates	Lower Endplates	Endplate Bolts	Head Assembly*
<b>MODEL 70 - 01' SERIES</b>									
1"	DM 20 Series NB Pipe	DLT55PYIG3816	DLT70PYD13816	DLT70MADA0001	DLT70MAHD0001	DLT70PYEU0001	DLT70PYEL0001	MS51595-61 10-24 x 3/8" Flat Socket Cap	DLT70PYHA3816
1-1/4"		DLT55PYIG3820	DLT70PYD13820						DLT70PYHA3820
1-1/2"		DLT55PYIG3824	DLT70PYD13824						DLT70PYHA3824
2"		DLT70PYIG3832	DLT70PYD13832						DLT70PYHA3832
<b>MODEL 70 - 02' SERIES</b>									
2-1/2"	DP 40 Series Low Pressure NB Pipe	DLT70PYIG4040	DLT70PYD14040	DLT70MADA0002	DLT70MAHD0002	DLT70PYEU0002	DLT70PYEL0002	MS51595-61 10-24 x 3/8" Flat Socket Cap	DLT70PYHA4040
3"		DLT70PYIG4048	DLT70PYD14048						DLT70PYHA4048

# OD TUBE – DM 60 SERIES – TOOL PARTS MATRIX (NEW GENERATION TOOL)

\*Head Assembly Includes: Die Set, Die Block, Head, Endplates and Endplate Bolts

## MODEL 10 POWER UNIT - DLT10MAPW0000

Size		Fitting Series	Inspection Gauge	Die Set	Die Block	Head	Upper Inboard	Lower Outboard	Lower Inboard	Lower Outboard	Head Assembly*
mm	inch										
<b>MODEL 10 - 01' SERIES</b>											
6.35	1/4"	DM 60 Series OD Imperial Tube	DLT10PYIG3704	DLT10PYDI3704	DLT10MADA0001	DLT10MAHD0001	DLT10PSEU4006	DLT10PYFU704	DLT10PSEL4006	DLT10PSFL4006	DLT10PYHA3704

## MODEL 40 POWER UNIT - DLT40MAPW0000

Size		Fitting Series	Inspection Gauge	Die Set	Die Block	Head	Upper Endplates	Lower Endplates	Endplate Bolts	Head Assembly*
mm	inch									
<b>MODEL 40 - 00' SERIES</b>										
9.53	3/8"	DM 60 Series OD Imperial Tube	DLT40PYIG3706	DLT40PYDI3706	DLT40MADA0000	DLT40MAHD0000	DLT40PYEU0000	DLT40PYEL0000	MS51595-61 10-24 x 3/8" Flat Socket Cap	DLT40PYHA3706
12.7	1/2"		DLT40PYIG3708	DLT40PYDI3708						DLT40PYHA3708
15.88	5/8"		DLT40PYIG3710	DLT40PYDI3916						DLT40PYHA3916
<b>MODEL 40 - 02' SERIES</b>										
19.05	3/4"	DM 60 Series OD Imperial Tube	DLT40PYIG3712	DLT40PYDI3712	DLT40MADA0002	DLT40MAHD0002	DLT40PYEU0002	DLT40PYEL0002	MS51595-61 10-24 x 3/8" Flat Socket Cap	DLT40PYHA3712
25.4	1"		DLT40PYIG3716	DLT40PYDI3716						DLT40PYHA3716

## MODEL 55 POWER UNIT - DLT55MAPW0000

Size		Fitting Series	Inspection Gauge	Die Set	Die Block	Head	Upper Endplates	Lower Endplates	Endplate Bolts	Head Assembly*
mm	inch									
<b>MODEL 55 - 01' SERIES</b>										
25.4	1"	DM 60 Series OD Imperial Tube	DLT40PYIG3716	DLT55PYDI3716	DLT55MADA0001	DLT55MAHD0001	DLT55PYEU0001	DLT55PYEL0001	MS51595-61 10-24 x 3/8" Flat Socket Cap	DLT55PYHA3716
31.75	1-1/4"		DLT55PYIG3720	DLT55PYDI3720						DLT55PYHA3720
38.1	1-1/2"		DLT55PYIG3724	DLT55PYDI3724						DLT55PYHA3724
50.8	2"		DLT55PYIG3732	DLT55PYDI3824						DLT55PYHA3824

# METRIC TUBE – DM 80 / DP 04 SERIES – TOOL PARTS MATRIX (NEW GENERATION TOOL)

\*Head Assembly Includes: Die Set, Die Block, Head, Endplates and Endplate Bolts

## MODEL 10 POWER UNIT - DLT10MAPW0000

Size	Fitting Series	Inspection Gauge	Die Set	Die Block	Head	Upper Inboard	Upper Outboard	Lower Inboard	Lower Outboard	Head Assembly*
<b>MODEL 10 - 01' SERIES</b>										
6 mm	<b>DM 80 Series Metric Tube</b>	DLT10PYIG3906	DLT10PYDI3704	DLT10MADA0001	DLT10MAHD0001	DLT10PSEU4006	DLT10PYFU704	DLT10PSEL4006	DLT10PSFL4006	DLT10PYHA3704
8 mm		DLT10PYIG3908	DLT10PYDI3908							DLT10PYHA3908

## MODEL 40 POWER UNIT - DLT40MAPW0000

Size	Fitting Series	Inspection Gauge	Die Set	Die Block	Head	Upper Endplates	Lower Endplates	Endplate Bolts	Head Assembly*
<b>MODEL 40 - 00' SERIES</b>									
10 mm	<b>DM 80 Series Metric Tube</b>	DLT40PYIG3910	DLT40PYDI3910	DLT40MADA0000	DLT40MAHD0000	DLT40PYEU0000	DLT40PYEL0000	MS51595-61 10-24 x 3/8" Flat Socket Cap	DLT40PYHA3910
12 mm		DLT40PYIG3912	DLT40PYDI3912						DLT40PYHA3912
14 mm		DLT40PYIG3914	DLT40PYDI3804						DLT40PYHA3804
15 mm		DLT40PYIG3915	DLT40PYDI3916						DLT40PYHA3916
16 mm	DLT40PYIG3916	DLT40PYDI3916	DLT40PYHA3916						
18 mm	DLT40PYIG3918	DLT40PYDI3806	DLT40PYHA3806						
20 mm	DLT40PYIG3920	DLT40PYDI3920	DLT40PYHA3920						
<b>MODEL 40 - 02' SERIES</b>									
22 mm	<b>DM 80 Series Metric Tube</b>	DLT40PYIG3922	DLT40PYDI3808	DLT40MADA0002	DLT40MAHD0002	DLT40PYEU0002	DLT40PYEL0002	MS51595-61 10-24 x 3/8" Flat Socket Cap	DLT40PYHA3808
25 mm		DLT40PYIG3925	DLT40PYDI3925						DLT40PYHA3925
28 mm		DLT40PYIG3928	DLT40PYDI3812						DLT40PYHA3812
30 mm		DLT40PYIG3930	DLT40PYDI3930						DLT40PYHA3930

# METRIC TUBE – DM 80 / DP 04 SERIES – TOOL PARTS MATRIX (NEW GENERATION TOOL)

\*Head Assembly Includes: Die Set, Die Block, Head, Endplates and Endplate Bolts

## MODEL 55 POWER UNIT – DLT55MAPW0000

Size	Fitting Series	Inspection Gauge	Die Set	Die Block	Head	Upper Endplates	Lower Endplates	Endplate Bolts	Head Assembly*
<b>MODEL 55 - 01' SERIES</b>									
30 mm	<b>DM 80 Series Metric Tube</b>	DLT40PYIG3930	DLT55PYDI3930	DLT55MADA0001	DLT55MAHD0001	DLT55PYEU0001	DLT55PYEL0001	MS51595-61 10-24 x 3/8" Flat Socket Cap	DLT55PYHA3930
35 mm		DLT40PYIG3935	DLT55PYDI3816						DLT55PYHA3816
38 mm		DLT55PYIG3938	DLT55PYDI3724						DLT55PYHA3724
42 mm		DLT55PYIG3942	DLT55PYDI3820						DLT55PYHA3820
50 mm		DLT55PYIG3950	DLT55PYDI3824						DLT55PYHA3824
44.5 mm	<b>DP 04 Series Low Pressure Metric Tube</b>	DLT55PYIG4244	DLT55PYDI3944	DLT56MADA0001	DLT55MAHD0001	DLT55PYEU0001	DLT55PYEL0001	MS51595-61 10-24 x 3/8" Flat Socket Cap	DLT55PYHA3944
<b>MODEL 55 - 02' SERIES</b>									
57 mm	<b>DP 04 Series Low Pressure Metric Tube</b>	DLT55PYIG4257	DLT55PYDI3957	DLT56MADA0002	DLT55MAHD0002	DLT55PYFU4032 DLT55PYEU4032	DLT55PYEL4032 DLT55PYFL4032	MS51595-61 10-24 x 3/8" Flat Socket Cap	DLT55PYHA3957

## MODEL 70 POWER UNIT – DLT70MAPW0000

Size	Fitting Series	Inspection Gauge	Die Set	Die Block	Head	Upper Endplates	Lower Endplates	Endplate Bolts	Head Assembly*
<b>MODEL 70 - 01' SERIES</b>									
42 mm	<b>DM 80 Series Metric Tube</b>	DLT55PYIG3942	DLT70PYDI3820	DLT70MADA0001	DLT70MAHD0001	DLT70PYEU0001	DLT70PYEL0001	MS51595-61 10-24 x 3/8" Flat Socket Cap	DLT70PYHA3820
50 mm		DLT55PYIG3950	DLT70PYDI3824						DLT70PYHA3824
60 mm		DLT70PYIG3960	DLT70PYDI3832						DLT70PYHA3832

# Tube-Mac<sup>®</sup> Flaring Tooling



## FLARING MACHINE

**Part Number: TFM-01-220** (220V/10/50Hz)

Weight: 417 kg

Available for hire or purchase.

Contact Prochem for details.

## FLARING PIN

Part Number	Sizes
TL-0011A	1/2" to 1" NB Pipe 6.35 (1/2") to 31.75 mm (1-1/4") OD Tube 12 to 30 mm Metric Tube
TL-0012A	1-1/4" and 1-1/2" NB Pipe 38.1 (1-1/2") to 50.8 mm (2") OD Tube 38 to 50 mm Metric Tube
TL-0013A	2" and 2-1/2" NB Pipe 60 mm and 75 mm Metric Tube
TL-0014A	3" NB Pipe 90 mm Metric Tube
TL-0017A	3-1/2" NB Pipe 100 mm Metric Tube
TL-0018A	4" NB Pipe 115 mm Metric Tube

## METRIC TUBE DIE

Part Number	Description
PFD-M12	12 mm die
PFD-M16	16 mm die
PFD-M20	20 mm die
PFD-M25	25 mm die
PFD-M30	30 mm die
PFD-M38	38 mm die
PFD-M42	42 mm die
PFD-M50	50 mm die
PFD-M60	60 mm die
PFD-M75	75 mm die
PFD-M90	90 mm die
PFD-M100	100 mm die
PFD-M115	115 mm die

## SPARE SHAFT SUPPORT

Part Number	Description
32304	Inner Shaft Support
NJ2305E.TVP2	Outer Shaft Support
TFM01-SK	Spare Seal Kit

## NB PIPE DIE

Part Number	Description
PFD-050	1/2" die
PFD-075	3/4" die
PFD-100	1" die
PFD-125	1-1/4" die
PFD-150	1-1/2" die
PFD-200	2" die
PFD-250	2-1/2" die
PFD-300	3" die
PFD-350	3-1/2" die
PFD-400	4" die

## OD TUBE DIE

Part Number	Description
TFD-050	6.35 mm (1/2") die
TFD-075	19.05 mm (3/4") die
TFD-100	25.4 mm (1") die
TFD-125	31.75 mm (1-1/4") die
TFD-150	38.1 mm (1-1/2") die
TFD-200	50.8 mm (2") die