

# Installation Manual

**PYPLOK<sup>®</sup>**

**F I T T I N G S**

**A Tube-Mac<sup>®</sup> Manufactured Product**

**Non-Welded Mechanically  
Attached Fittings**

## **EC Declaration of Conformity**

### **for machinery**

According to annex II 1A of Machinery Directive 2006/42/EC in the current version

---

The Manufacturer

**Tube-Mac Piping Technologies Ltd.**

853 Arvin. Ave

Stoney Creek, ON CANADA

L8E 5N8

declares under sole responsibility that the "Interchangeable Equipment" described below:

**Designation:**

**PYPLOK®**

**Types and tradenames:**

**DLT10, DLT20, DLT40, DLT55, DLT70, DLT86**

Characteristic:

Interchangeable Equipment driven by hydraulic supply used for swaging of pipe connectors:  
From May 2016 on

complies with all relevant provisions of the EC-Directives 2006/42/EC (Machinery) and 2014/68/EU (Pressure Equipment). The following harmonised standards are applied:

- EN ISO 12100: 2010: Safety of Machinery, Principles
- EN ISO 4413: 2010, hydraulic equipment

The technical file of these products are compiled by:

**Tube-Mac Piping Technologies GmbH**

Egon-Schiele-Straße 1

4614 Marchtrenk, Austria

By modification to the machine as well as to non-compliance with the provisions of the operation manual, this declaration loses its validity.











# Installation Manual

## Table of Contents

Safety	Page 2
Tool Parts and Equipment	Page 3
Pipe/Tube Preparation	Page 6
Pipe/Tube Verification	Page 8
Pipe/Tube Marking	Page 8
Fitting Position and Alignment on Pipe/Tube	Page 9
Swage Sequence	Page 10
Tool Operation	Page 11
Swage and Installation Inspection	Page 12
Trouble Shooting	Page 13
Tool Maintenance & Troubleshooting	Page 14
PYPLOK® Tool Matrix	Page 15
Pipe and Tube Qualification	Page 20

# Installation Manual

## Safety

	<p>Read all instructions, warnings and cautions carefully. Follow all safety precautions to avoid personal injury or property damage during system operation. Tube-Mac® cannot be responsible for damage or injury resulting from unsafe product use, lack of maintenance or incorrect product and or system operation. Contact Tube-Mac® when in doubt as to the safety precautions and operations. Only trained personnel with certified PYPLOK® Installer Training cards are permitted to operate the tooling.</p>
	<p>To avoid personal injury keep hands/fingers away from crimping head and moving parts during operation. Keep face at a position away from the tool and in an area that allows for visual operation of the tool and crimping process.</p>
	<p>Before operating tool perform a visual inspection of PYPLOK® swaging tool including the power unit and head assembly for any possible cracks, damage or tool wear.</p>
	<p>Never operate the PYPLOK® Tool without the head assembly properly engaged to the power unit as improper engagement can damage the tool.</p>
	<p>Wear proper PPE when operating hydraulic and crimping equipment.</p>
	<p>The system and pump pressure must not exceed the PYPLOK® Tooling maximum allowable operating pressure of 10,000 PSI/690 bar. Never set the relief valve pressure on any pump higher than 10,000 PSI/690 bar. Higher settings may result in equipment damage and or personal injury.</p>
	<p>Check and secure hose connections before operating the PYPLOK® swaging tool. Make sure hose is not kinked or bent. Assemble all equipment properly before operation. Check and secure hose connections before operating the PYPLOK® swaging tool.</p>
	<p>Certain PYPLOK® Tooling can be heavy. Take care when lifting and transporting the tools. Do not lift the PYPLOK® Tooling equipment by the hose or swivel couplers. Use the carrying handles or other means to handle the tooling in a safe manner.</p>
	<p>PYPLOK® Tooling is to only be serviced by a qualified PYPLOK® Technician. For repair and service contact the Authorized PYPLOK® Dealer for more information. DO NOT ATTEMPT TO SERVICE THE TOOL. Tooling is to be serviced every 10,000 cycles or 5 years (whichever comes first) and is the responsibility of the owner to contact the local PYPLOK® Dealer for Tooling Service Assistance.</p>
	<p>Immediately stop operation of the equipment if any parts show wear or damage. Contact your local PYPLOK® Dealer for part replacement and or tooling service.</p>

### FORSEEABLE MISUSE WARNING:

**FAILURE OR IMPROPER SELECTION OR IMPROPER USE OF THE PRODUCT  
CAN CAUSE DEATH, PERSONAL INJURY AND PROPERTY DAMAGE.**

# Installation Manual

## PYPLOK® Swaging Tool Parts and Equipment

WARNING

TOOL TO BE OPERATED BY QUALIFIED TRAINED PERSONNEL ONLY. REFER TO PYPLOK INSTALLATION MANUAL FOR PROPER OPERATING METHODS AND SAFE PRACTICES. DUE TO HIGH SWAGING FORCES, HEAD AND UPPER SECTION OF POWER UNIT MUST BE FULLY ENGAGED AND FLUSH ON BOTH SIDES. PARTIAL ENGAGEMENT MAY CAUSE TOOL FAILURE. SWIVEL AND QUICK CONNECT ASSEMBLY MUST BE INSTALLED PROPERLY BEFORE OPERATION OF PUMP. MAXIMUM ALLOWABLE OPERATING PRESSURE MUST NOT EXCEED 10,000 PSI / 690 BAR.

WARNING

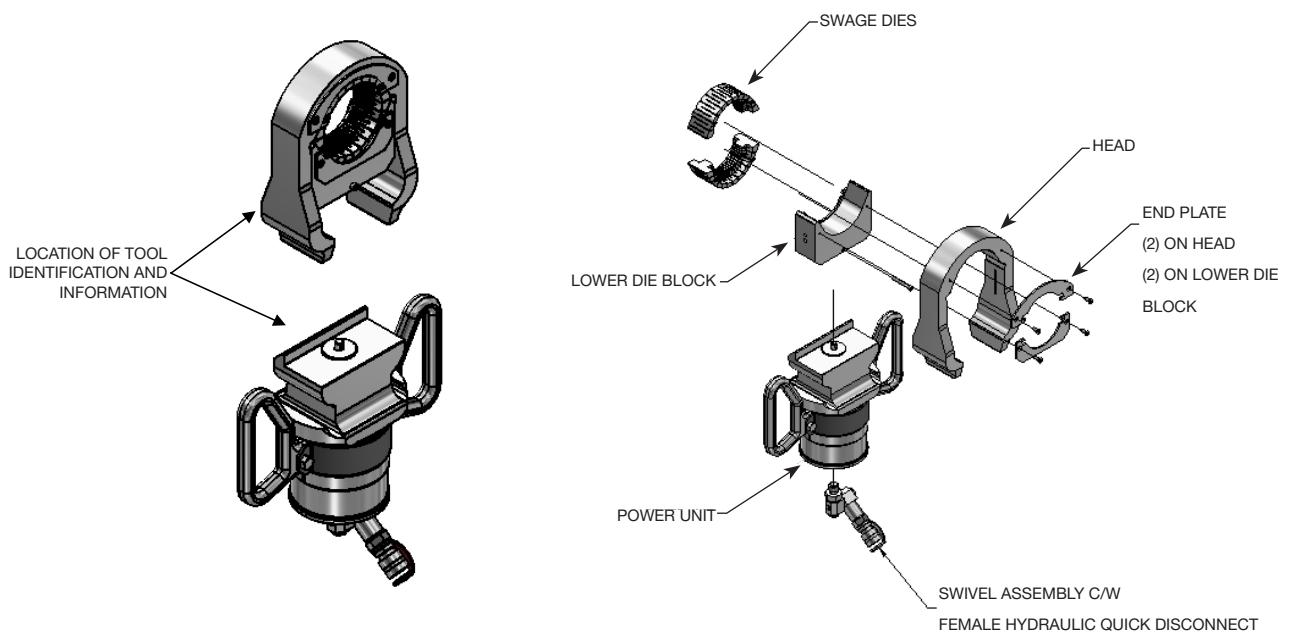

1. The PYPLOK® Tooling is intended for installing PYPLOK® Fittings in a safe and efficient manner. The operation of the tooling by means of an external hydraulic supply to crimp the PYPLOK® Fitting into place on matching tube or piping systems for a permanent, leak free, non-welded connection.
2. Select appropriate swage die set, apply swage lube to the bottom surface of the dies and landing areas of Lower Die Block and Head then insert (1) half of die set into lower die block and (1) half of die set into head. Attach endplates with bolts ensuring the tabs of the swage dies are located in the open slots of the endplates. Note that MSDS information for swage lube is available upon request and prolonged skin contact should be avoided although it is non-hazardous.
3. Check to ensure that the swage dies are located properly within the endplates and can move freely when pushed down.
4. Follow the above process when changing swage die sets for other sizes.
5. Used dies are to be inspected for debris and cleaned if required. Clean with pressurized air, soft brush or hand cloth removing all old swage lube and debris within the die slots and other surfaces.

# Installation Manual

## PYPLOK® Swaging Tool Parts and Equipment

This manual covers the following PYPLOK® Tooling Series which have the following size range capabilities. For more detailed part numbers and tool selection see Tool Matrix Section on pages 15-19:

DLT10 – 1/4" OD and 6mm-8mm

DLT20 – 1/4"-3/8" NPS, 1/4"-5/8" OD and 6mm-16mm

DLT40 – 1/4"-3/4" NPS, 3/8"-1" OD and 8mm-30mm

DLT55 – 1/2"-1-1/2" NPS, 1"-2" OD and 22mm-50mm

DLT70 – 1"-3" NPS, 1-1/2"-2" OD and 35mm-60mm

DLT86 – 3"-4" NPS

All tooling has the following information for selection and identification:

- A) Company/Product Name
- B) Design Series/Part Number
- C) Serial Number as designated by S/N
- D) Material Traceability Code
- E) Country of Manufacture designated by CAN = Canada
- F) Manufacture/Assembly Date indicated by week – year format

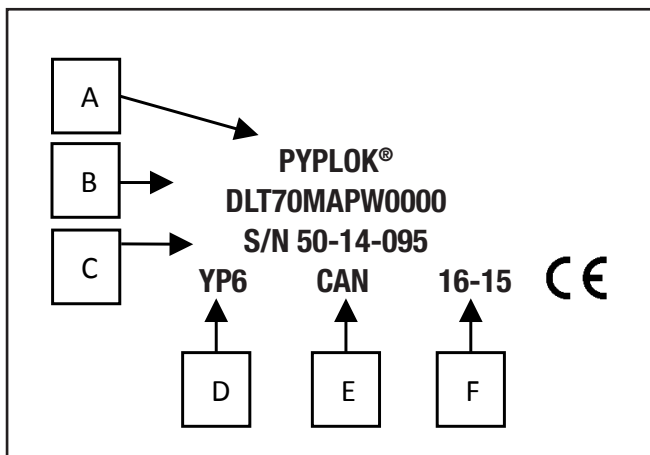

# Installation Manual

## PYPLOK® Swaging Tool Pump Requirements

1. Depending on application and environment the choice of Electric, Battery, Pneumatic or Hand Operated pumps can be used.
2. The hydraulic pumps used for operation of the PYPLOK® Tooling must be capable of producing up to but not exceeding 10,000 PSI/690 bar and have internal relief valve to prevent pump from producing more than 10,000 PSI/690 bar within the PYPLOK® Tools.
3. Power operated pumps must operate in hold-to-run mode (hydraulic supply only as long as push-button or pedal is activated, hydraulic Stop or Release when push-button or pedal are released). PYPLOK® has defined PL = c (EN ISO 13849) as requirement for the control circuit.
4. The hydraulic hose and quick connectors joining the pump to the PYPLOK® Tooling must be rated for use with a 10,000 PSI/690 bar Pump.

## The Following Pumps Are Offered by Tube-Mac® for Use with the PYPLOK® Tooling:



WUD1100EU100 – 220 Volt Electric Pump complete with 10,000 PSI non-conductive hose

WUD1100BU100 – 110 Volt Electric Pump complete with 10,000 PSI non-conductive hose



P392 – Hand Pump complete with 10,000 PSI non-conductive hose



XA11G – Pneumatic Pump complete with 10,000 PSI non-conductive hose



B70M-P24 – Battery Pump complete with 10,000 PSI non-conductive and 110V Battery Charger

B70M-P24-220 – Battery Pump complete with 10,000 PSI non-conductive and 220V Battery Charger



The system and pump pressure must not exceed the PYPLOK® Tooling maximum allowable operating pressure of 10,000 PSI/690 Bar. Never set the relief valve pressure on any pump higher than 10,000 PSI/690 Bar. Higher settings may result in equipment damage and or personal injury.

# Installation Manual

## Pipe Preparation

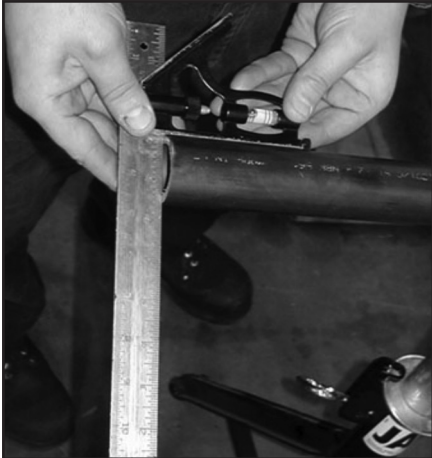

- Cut the pipe to desired length.
- Ensure that cut is square but up to 5° off square is acceptable.



- The pipe must be free of any scale, rust, paint, lacquer and any major scratches, gouges or weld seams.
- Use aluminum oxide cloth grit 80-400 or an abrasive wheel/tool to remove all debris from the pipe down to bare metal.
- It is important to note that all cleaning of the external pipe must only be done radially around the pipe and not longitudinally.
- Do not use a grinder or any other tool that will leave a rough, uneven or flat surface after cleaning.
- Do not use a wire wheel to attempt to remove lacquer.



- Deburr outside diameter of pipe with a file and the inside diameter with an internal deburring tool.
- It is critical to remove all sharp edges to prevent damage to the PYPLOK® fitting seals.



# Installation Manual

## Pipe Preparation - Special Notice

### Carbon Steel Pipe With Surface Treatment

Special attention must be taken when using Carbon pipe with surface applications including lacquer, paint, galvanizing and other treatments. All surface treatments must be completely removed as per Pipe Preparation methods listed so that the sealing surface of the pipe is bare metal. If the sealing area is not cleared down to bare, smooth metal proper sealing of the PYPLOK® Fitting will be limited. Examples of improper pipe surfaces are found below:

**Surface Not Cleaned**

**Lacquer Not Removed  
From Pipe**

**Surface Properly Cleaned/  
Bare Metal Surface**

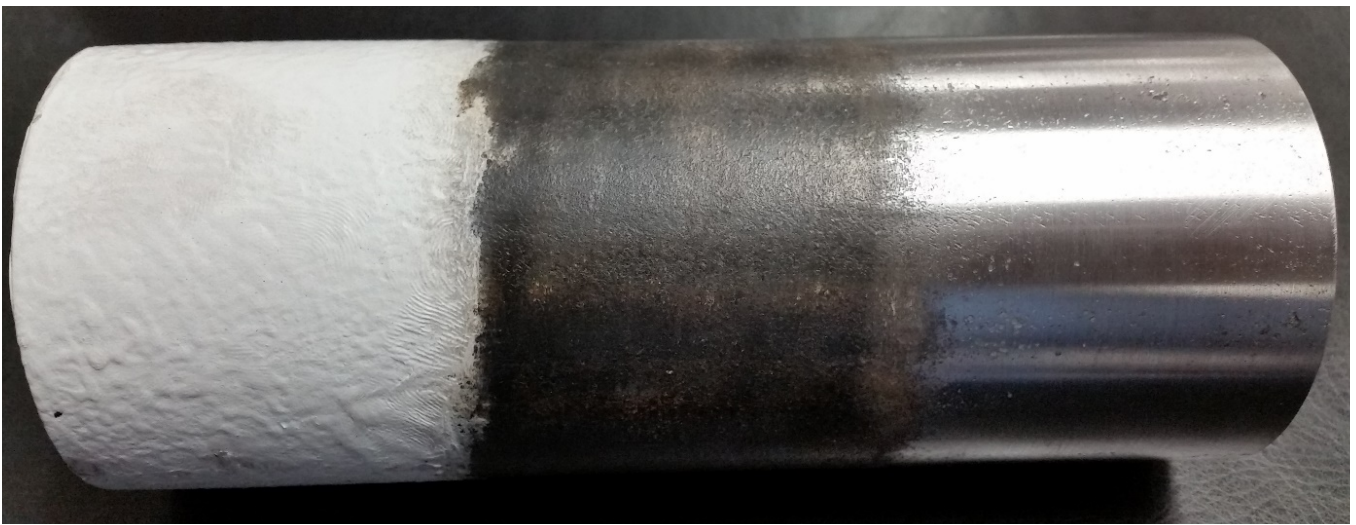

### Gas Applications

Gases such as nitrogen are made of tiny molecules able to go through the smallest leak paths on pipe surfaces. Any foreign debris including surface treatments and or gouges/scratches can cause leaks. The most reliable connection is achieved when proper installation instructions are followed including very specific pipe surface preparation. Whenever possible, heavier pipe wall thickness should be used to offer a more reliable seal as the heavier wall will offer more resistance to the compressed fitting compared to thin wall. It may be required to pressure test a gas system to a much greater level than the operational pressure required. This will help set the pipe against the compressed fitting. Therefore, it is acceptable to pressure test the system to the maximum design pressure of the fittings or pipe (whichever is the lower value) in accordance with national and local regulations.

# Installation Manual

## Verify Diameter of the Pipe Using the Inspection Gauge

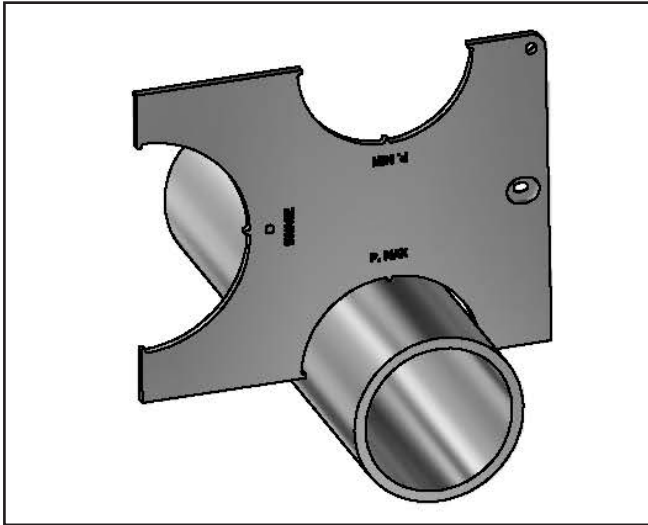

- P. Max gauge should fit 360° around the pipe. The area of the pipe to be inspected is the location where the fitting is intended to be installed.

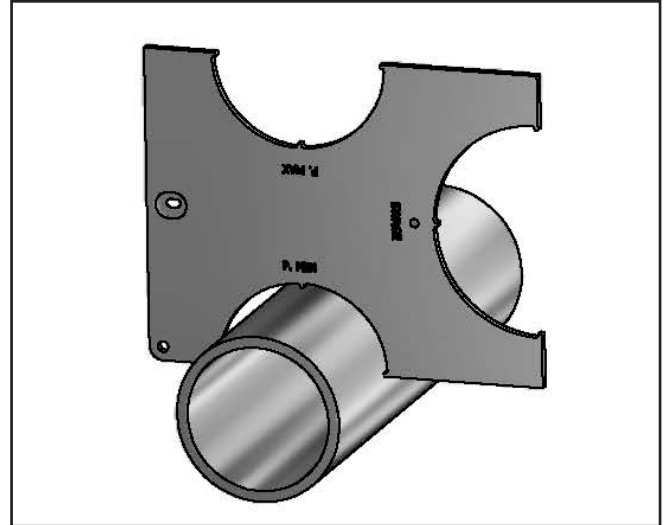

- P. Min gauge should not be able to fit at any point 360° around pipe. The area of the pipe to be inspected is the location where the fitting is intended to be installed.

**Note: If these criteria are not met, then a new location on the existing line that is acceptable must be used or the pipe cannot be used and new material is required. Pipe that does not meet the required dimension may not properly operate after crimping.**

## Pipe Marking

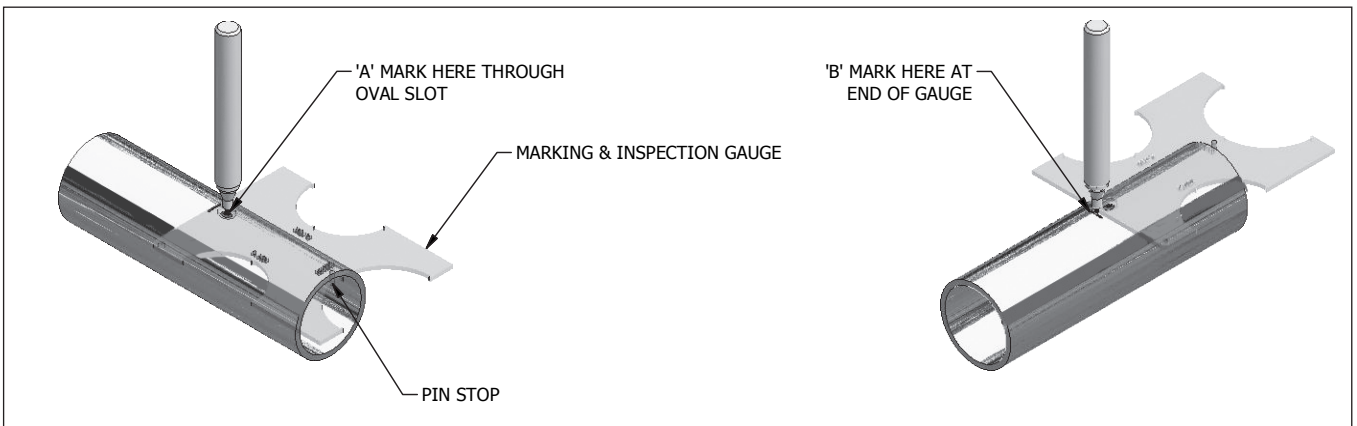

- Position the inspection gauge on the pipe with the pin stop pressed up against the pipe end as shown.
- Make the “A” oval mark on the pipe through the oval marking slot in gauge.
- Make the “B” line mark at the end of the gauge.

**Note: The minimum space between two fittings is 2x Pipe/Tube Diameter. This allows for the inspection gauge to fit between two connections for inspection and proper operation of the fitting. It must also be noted that no fitting can be installed within the radius of a bend and only straight pipe section can be used.**

# Installation Manual

## Coupling Position and Alignment

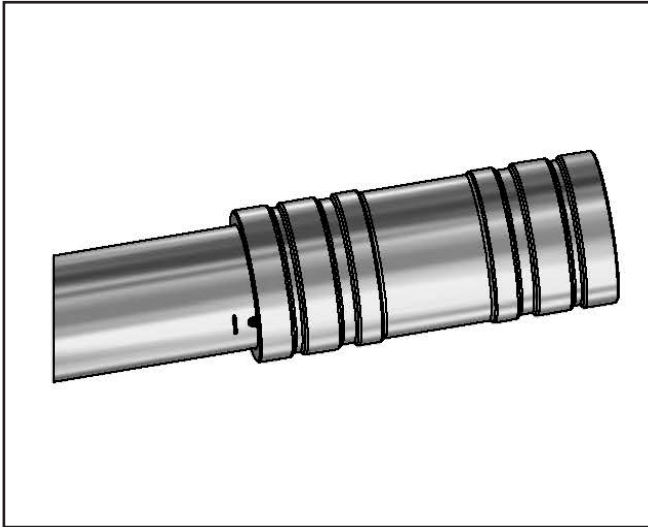

- Slide the coupling on to the end of pipe to first mark which is oval shaped.
- The edge of the coupling must touch any part of the oval mark.

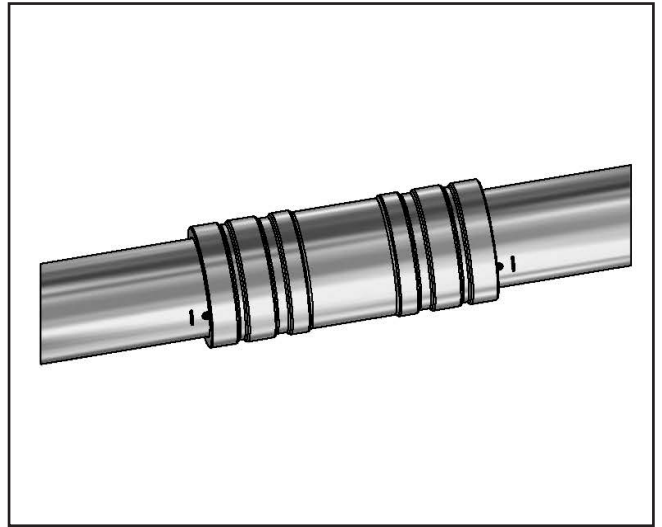

- Insert end of other pipe into coupling so the ends of pipe touch inside of the coupling.
- The markings should be visible as shown.

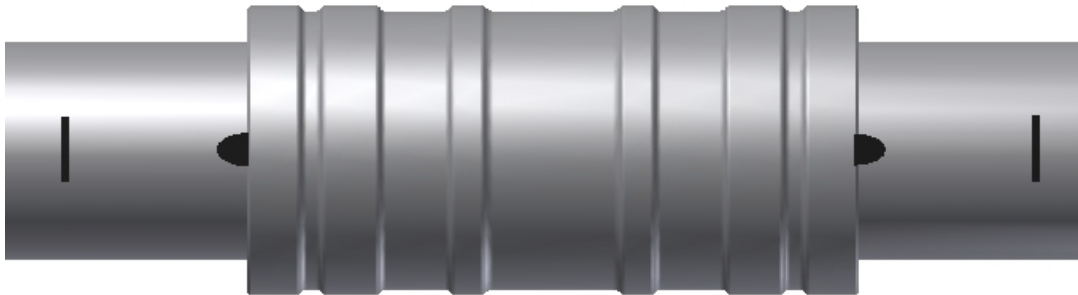

# Installation Manual

## Swage Sequence

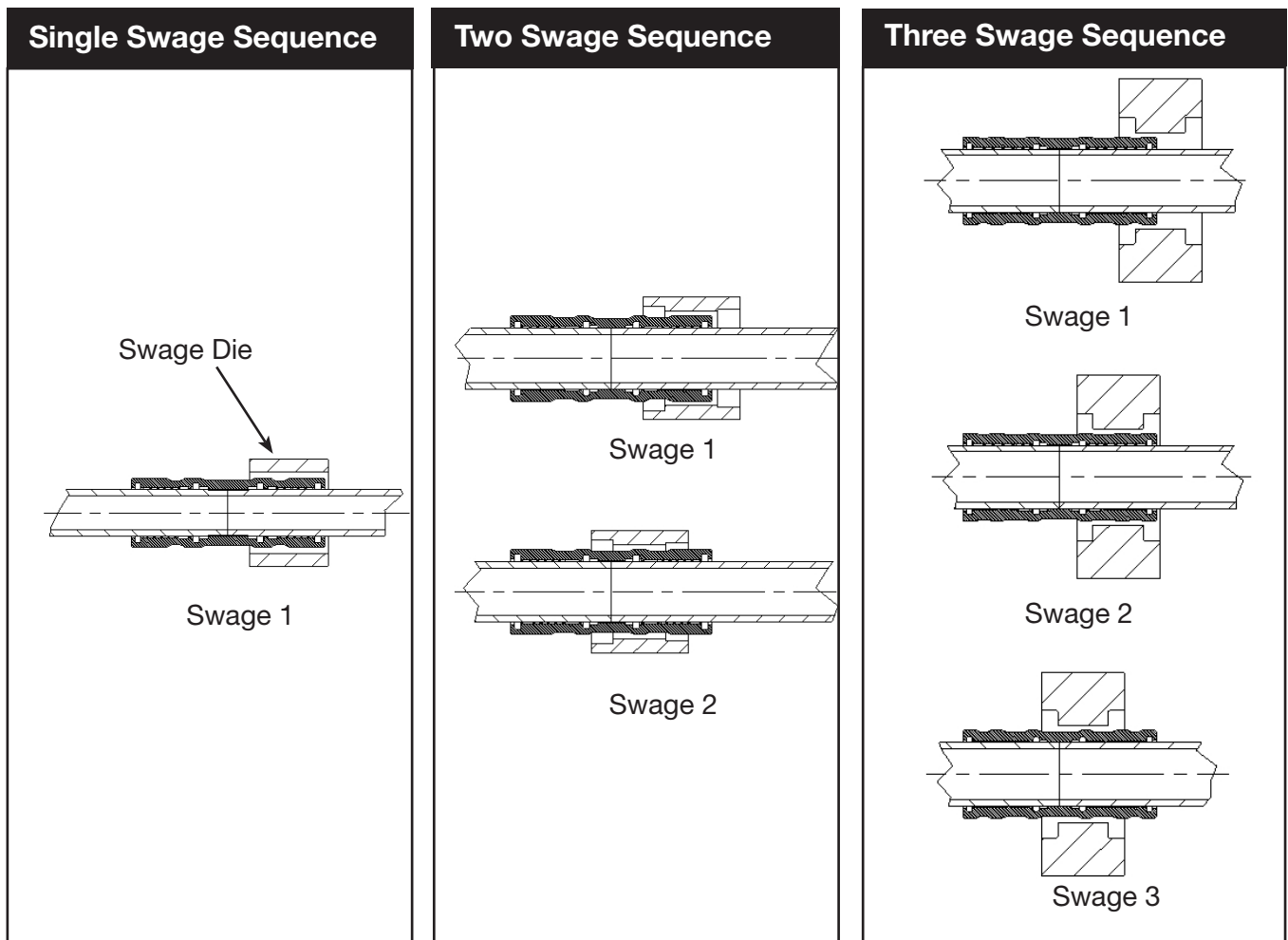

- All raised surfaces on coupling must be swaged.
- Swaging order is shown above for 1 swage, 2 swage and 3 swage configurations which varies by fitting size, series and tool model.
- Always start with the outside swage first and work towards the middle of the coupling.

**Note: For heavy wall pipe and duplex/super duplex fittings two swages maybe required per band. Swage at location, rotate PYPLOK® Tool 90° and swage again. This is only required if the inspection gauge does not pass over the swage band after original swage or for low pressure gas applications.**

# Installation Manual

## Tool Operation and Die Engagement

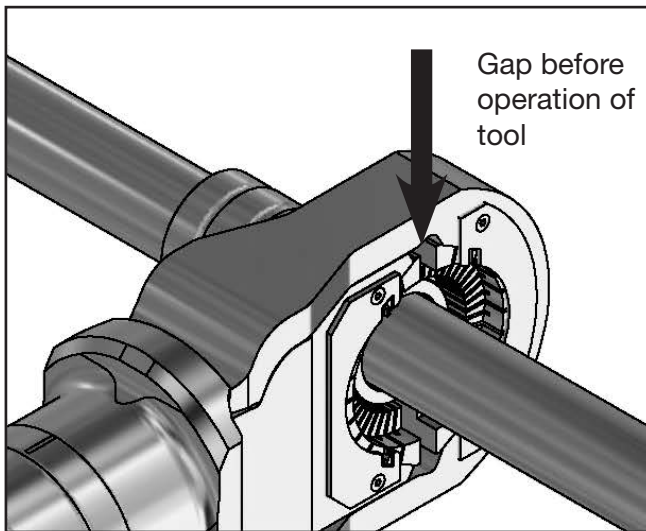

- Before swaging notice the gap between head assemblies.
  - The hydraulic power pack being electric, hand and or pneumatic are required to produce the required pressure and oil flow for the PYPLOK® Tool to operate.
  - Note that the PYPLOK® Tooling does not have noise emission >70dB(A).

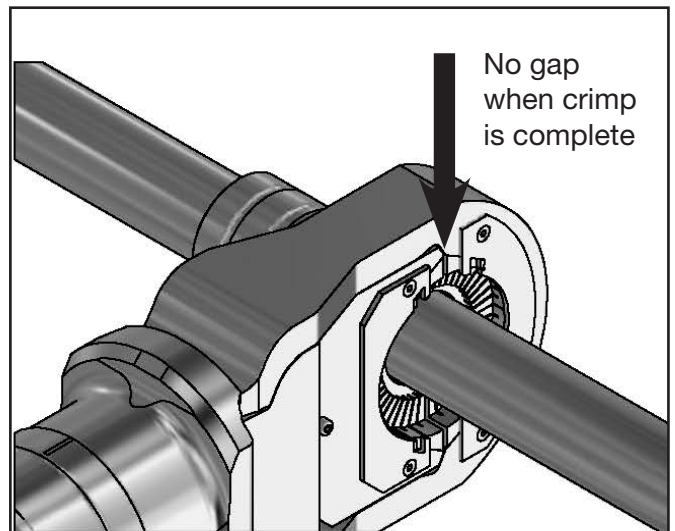

- To swage; turn on the power pack. The pressure from the power unit forces the lower die block and upper head assembly together thus swaging the fitting on the pipe or tube.
- The swage is complete when the head bottoms out and the gap closes.
- In cases where a pump with a 10,000 PSI/ 690 bar relief is available, the tool will stop crimping and retract once 10,000 PSI/ 690 bar is achieved.

# Installation Manual

## Swage Inspection and Assembly

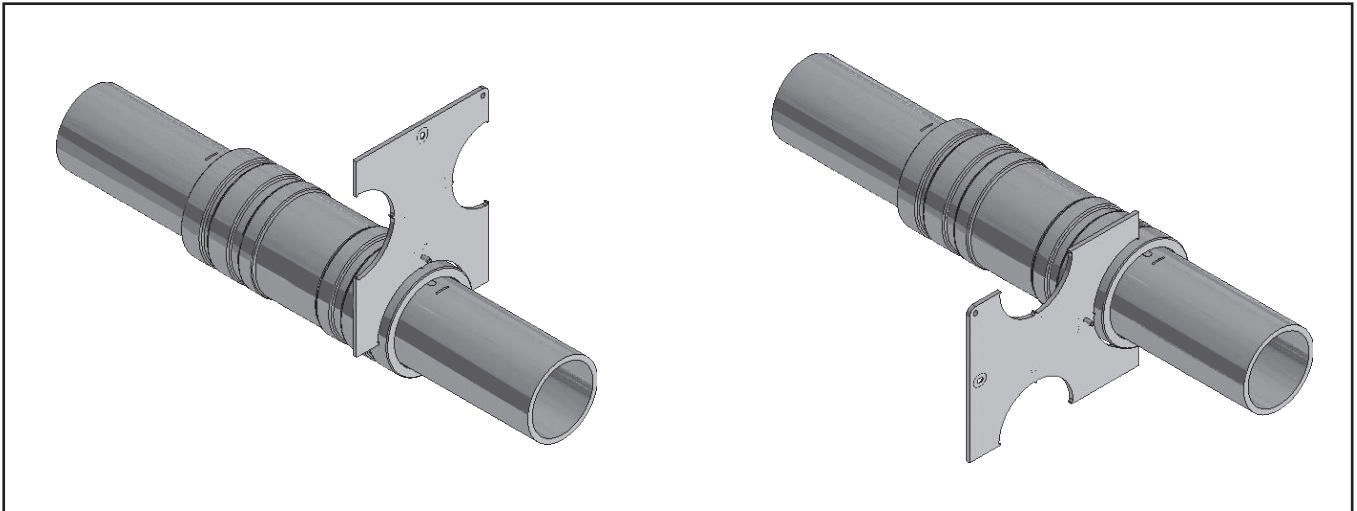

- Each swage band must be checked with the corresponding inspection gauge.
- The inspection gauge must fit freely around each swage band at two locations 90° from each other.

### Acceptable Crimp

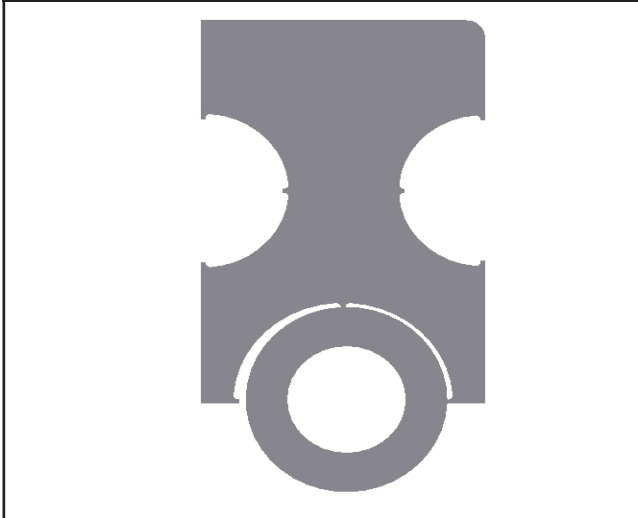

- 2 Point Contact, 90° Apart
- Acceptable Crimp

### Unacceptable Crimp

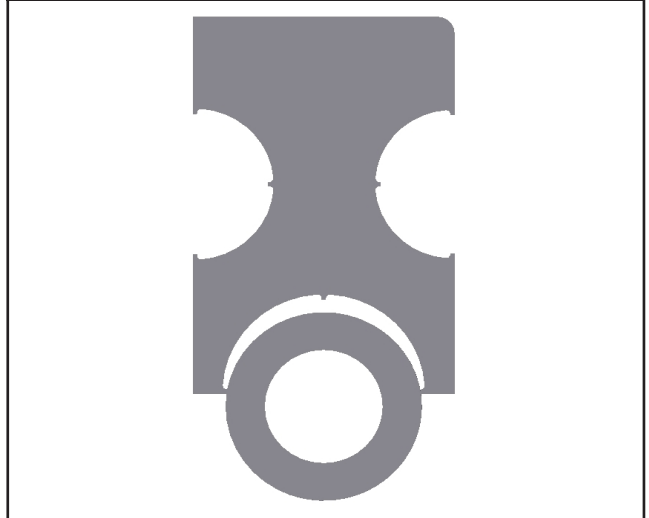

- 2 Point Contact, 180° Apart
- Indicates that diameter of fitting is oversized and need re-crimping

- If any area of the swage bands does not pass the inspection gauge the fitting must be re-swaged.
- It may be required to re-swage and then rotate the tool 90° and re-swage in certain situations.
- After re-swaging the fitting must be checked with the inspection gauge as per the above process.

# Installation Manual

## Swage and Installation Inspection

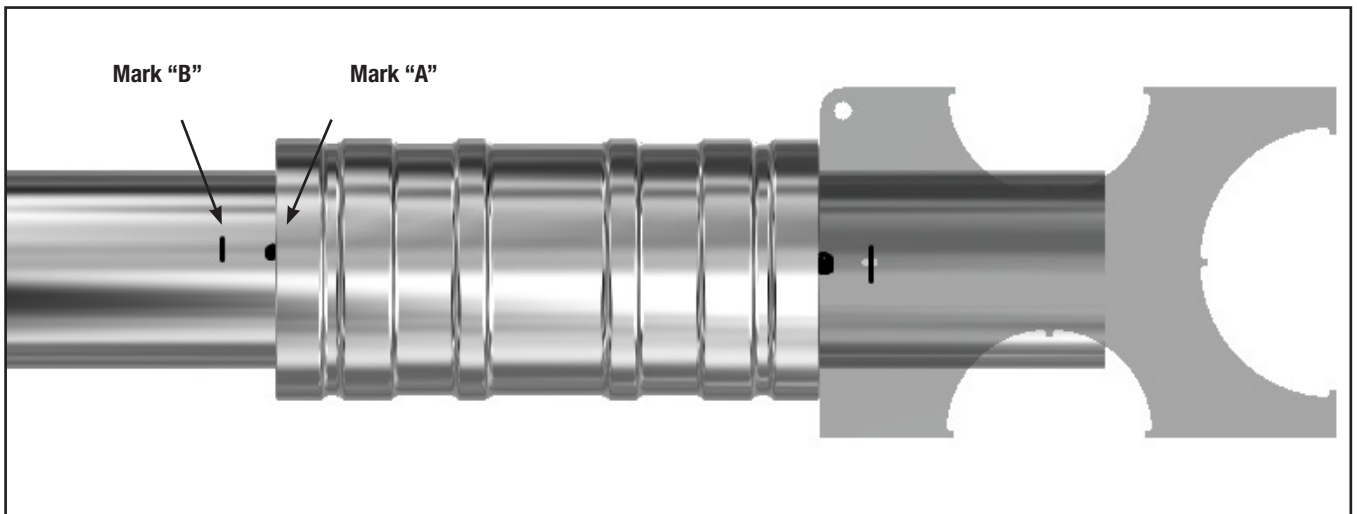

- Verify pipe insertion by observing that some portion of the pipe installation Mark “A” is beneath the fitting and that some portion of the mark is visible.
- In the event that the installation Mark “A” is not clearly visible, the inspection Mark “B” can be used to verify proper insertion.
- Position the marking tool against the fitting end, placing the side with the pin stop away from the pipe and verify that some portion of the inspection Mark “B” is visible in the gauge window or between the slot and the fitting end.

# Installation Manual

Trouble Shooting		
Problem	Possible Cause	Solution
Inspection gauge does not fit the pipe/tube correctly.	Wrong size or out of tolerance pipe/tube.	Check for the correct pipe size and also the correct inspection gauge.
Inspection gauge does not fit properly over the swaged fitting.	Complete swage not performed. Improper Pump pressure. Wrong die used, dirty, or worn.	Re-swage by rotating tool 90° from original crimp position. Check the pump pressure. Inspect/clean dies/head.
Insertion and Inspection marks are not visible or not lined up with fitting.	Fitting improperly located on pipe before swaging.	Replace fitting.
Tool will not retract after swaging.	Hose not properly connected to the Quick Disconnect.	Remove hose and reconnect properly to the Quick Disconnect.
Hose cannot connect to Quick Disconnect of Power Unit.	Pressure was not released fully after last use.	Push in the check valve plate in the hose and quick disconnect to release trapped pressure.

Tool Preventative Maintenance	
Procedure	Frequency
Check all components for deep scratches, gouges, cracks or other abnormal surface finish.	Before each use. Discontinue if noticed and contact supplier.
Check die inserts and head assemblies for foreign material or build up between die insert slots and head assembly.	Before each use. Clean with pressurized air, soft brush or hand cloth removing all old swage lube and debris within the die slots and other surfaces. Then apply new swage lube before use.
Inspect all Quick Disconnect and hose part to ensure no damage or loose threads.	Before each use. Tighten any loose threads and if any damage to part contact supplier.
Inspect/Re-calibrate Inspection Gauges.	After possible damage or based on owners gauges. Re-certification requirements. Dimensional drawings can be supplied for use by third party inspection and calibration.
Service Life Inspection/Re-certification.	Every 10,000 cycles or 5 years (whichever comes first). Tool must be sent back to Tube-Mac for full life service maintenance and re-certification.



# PYPLOK® Tool Matrix

## DM 20 Series - NPS Pipe

Model 40 Power Unit - DLT40MAPW0000										
Size	Fitting Series	Inspection Gauge	Die Set	Die Block	Head	Upper Endplates	Lower Endplates	Endplate Bolts	*Head Assembly	
Model 40-00' Series										
1/4"	DM 20 Series	DLT40PYIG3804	DLT40PYDI3804	DLT40MADA0000	DLT40MAHD0000	DLT40PYEU0000	DLT40PYEL0000	MS51595-61 10-24 x 3/8" Flat Socket Cap	DLT40PYHA3804	
3/8"		DLT40PYIG3806	DLT40PYDI3806						DLT40PYHA3806	
Model 40 - 02' Series										
1/2"	DM 20 Series	DLT40PYIG3808	DLT40PYDI3808	DLT40MADA0002	DLT40MAHD0002	DLT40PYEU0002	DLT40PYEL0002		DLT40PYHA3808	
3/4"		DLT40PYIG3812	DLT40PYDI3812					DLT40PYHA3812		

Model 55 Power Unit - DLT55MAPW0000									
Size	Fitting Series	Inspection Gauge	Die Set	Die Block	Head	Upper Endplates	Lower Endplates	Endplate Bolts	*Head Assembly
Model 55 - 01' Series									
1/2"	DM 20 Series	DLT40PYIG3808	DLT55PYDI3808	DLT55MADA0001	DLT55MAHD0001	DLT55PYEU0001	DLT55PYEL0001	MS51595-61 10-24 x 3/8" Flat Socket Cap	DLT55PYHA3808
3/4"		DLT40PYIG3812	DLT55PYDI3812						DLT55PYHA3812
1"		DLT55PYIG3816	DLT55PYDI3816						DLT55PYHA3816
1-1/4"		DLT55PYIG3820	DLT55PYDI3820						DLT55PYHA3820
1-1/2"		DLT55PYIG3824	DLT55PYDI3824						DLT55PYHA3824

Model 70 Power Unit - DLT70MAPW0000									
Size	Fitting Series	Inspection Gauge	Die Set	Die Block	Head	Upper Endplates	Lower Endplates	Endplate Bolts	*Head Assembly
Model 70 - 01' Series									
1"	DM 20 Series	DLT55PYIG3816	DLT70PYDI3816	DLT70MADA0001	DLT70MAHD0001	DLT70PYEU0001	DLT70PYEL0001	MS51595-61 10-24 x 3/8" Flat Socket Cap	DLT70PYHA3816
1-1/4"		DLT55PYIG3820	DLT70PYDI3820						DLT70PYHA3820
1-1/2"		DLT55PYIG3824	DLT70PYDI3824						DLT70PYHA3824
2"		DLT70PYIG3832	DLT70PYDI3832						DLT70PYHA3832

\*Head Assembly Includes: Die Set, Die Block, Head, Endplates and Endplate Bolts

# PYPLOK® Tool Matrix

## DM 60 Series - OD Tube

Model 10 Power Unit - DLT10MAPW0000										
Size	Fitting Series	Inspection Gauge	Die Set	Die Block	Head	Upper Inboard	Upper Outboard	Lower Inboard	Lower Outboard	*Head Assembly
Model 10 - 01' Series										
1/4"	DM 60 Series	DLT10PYIG3704	DLT10PYDI3704	DLT10MADA0001	DLT10MAHD0001	DLT10PSEU4006	DLT10PYFU704	DLT10PSEL4006	DLT10PSFL4006	DLT10PYHA3704

Model 20 Power Unit - DLT20MAPW0000										
Size	Fitting Series	Inspection Gauge	Die Set	Die Block	Head	Upper Endplates	Lower Endplates	Endplate Bolts	*Head Assembly	
Model 20 - 00' Series										
3/8"	DM 60 Series	DLT40PYIG3706	DLT20PYDI3706	DLT20MADA0001	DLT20MADA0000	DLT40PYEU0000	DLT40PYEL0000	MS51595-61 10-24 x 3/8" Flat Socket Cap	DLT20PYHA3706	
1/2"		DLT40PYIG3708	DLT20PYDI3708						DLT20PYHA3708	
5/8"		DLT40PYIG3710	DLT20PYDI3916						DLT20PYHA3916	

Model 40 Power Unit - DLT40MAPW0000										
Size	Fitting Series	Inspection Gauge	Die Set	Die Block	Head	Upper Endplates	Lower Endplates	Endplate Bolts	*Head Assembly	
Model 40 - 00' Series										
3/8"	DM 60 Series	DLT40PYIG3706	DLT40PYDI3706	DLT40MADA0000	DLT40MAHD0000	DLT40PYEU0000	DLT40PYEL0000	MS51595-61 10-24 x 3/8" Flat Socket Cap	DLT40PYHA3706	
1/2"		DLT40PYIG3708	DLT40PYDI3708						DLT40PYHA3708	
5/8"		DLT40PYIG3710	DLT40PYDI3916						DLT40PYHA3916	
Model 40 - 02' Series										
3/4"	DM 60 Series	DLT40PYIG3712	DLT40PYDI3712	DLT40MADA0002	DLT40MAHD0002	DLT40PYEU0002	DLT40PYEL0002	MS51595-61 10-24 x 3/8" Flat Socket Cap	DLT40PYHA3712	
1"		DLT40PYIG3716	DLT40PYDI3716						DLT40PYHA3716	

Model 55 Power Unit - DLT55MAPW0000										
Size	Fitting Series	Inspection Gauge	Die Set	Die Block	Head	Upper Endplates	Lower Endplates	Endplate Bolts	*Head Assembly	
Model 55 - 01' Series										
1"	DM 60 Series	DLT40PYIG3716	DLT55PYDI3716	DLT55MADA0001	DLT55MAHD0001	DLT55PYEU0001	DLT55PYEL0001	MS51595-61 10-24 x 3/8" Flat Socket Cap	DLT55PYHA3716	
1-1/4"		DLT55PYIG3720	DLT55PYDI3720						DLT55PYHA3720	
1-1/2"		DLT55PYIG3938	DLT55PYDI3938						DLT55PYHA3938	
2"		DLT55PYIG3732	DLT55PYDI3824						DLT55PYHA3824	

\*Head Assembly Includes: Die Set, Die Block, Head, Endplates and Endplate Bolts

# PYPLOK® Tool Matrix

## DM 80 Series - Metric Tube

### Model 10 Power Unit - DLT10MAPW0000

Size	Fitting Series	Inspection Gauge	Die Set	Die Block	Head	Upper Inboard	Upper Outboard	Lower Inboard	Lower Outboard	*Head Assembly
Model 10 - 01' Series										
6mm	DM 80 Series	DLT10PYIG3906	DLT10PYDI3704	DLT10MADA0001	DLT10MAHD0001	DLT10PSEU4006	DLT10PYFU704	DLT10PSEL4006	DLT10PSFL4006	DLT10PYHA3704
8mm		DLT10PYIG3908	DLT10PYDI3908							DLT10PYHA3908

### Model 20 Power Unit - DLT20MAPW0000

Size	Fitting Series	Inspection Gauge	Die Set	Die Block	Head	Upper Endplates	Lower Endplates	Endplate Bolts	*Head Assembly
Model 20 - 00' Series									
8mm	DM 80 Series	DLT40PYIG3908	DLT20PYDI3908	DLT20MADA0000	DLT20MAHD0000	DLT40PYEU0000	DLT40PYEL0000	MS51595-61 10-24 x 3/8" Flat Socket Cap	DLT20PYHA3908
10mm		DLT40PYIG3910	DLT20PYDI3910						DLT20PYHA3910
12mm		DLT40PYIG3912	DLT20PYDI3912						DLT20PYHA3912
15mm		DLT40PYIG3915	DLT20PYDI3916						DLT20PYHA3916
16mm		DLT40PYIG3916	DLT20PYDI3916						DLT20PYHA3916

### Model 40 Power Unit - DLT40MAPW0000

Size	Fitting Series	Inspection Gauge	Die Set	Die Block	Head	Upper Endplates	Lower Endplates	Endplate Bolts	*Head Assembly
Model 40 - 00' Series									
8mm	DM 80 Series	DLT40PYIG3908	DLT20PYDI3908	DLT40MADA0000	DLT40MAHD0000	DLT40PYEU0000	DLT40PYEL0000	MS51595-61 10-24 x 3/8" Flat Socket Cap	DLT40PYHA3908
10mm		DLT40PYIG3910	DLT40PYDI3910						DLT40PYHA3910
12mm		DLT40PYIG3912	DLT40PYDI3912						DLT40PYHA3912
14mm		DLT40PYIG3914	DLT40PYDI3804						DLT40PYHA3804
15mm		DLT40PYIG3915	DLT40PYDI3916						DLT40PYHA3916
16mm		DLT40PYIG3916	DLT40PYDI3916						DLT40PYHA3916
18mm		DLT40PYIG3918	DLT40PYDI3806						DLT40PYHA3806
20mm		DLT40PYIG3920	DLT40PYDI3920						DLT40PYHA3920
Model 40 - 02' Series									
22mm	DM 80 Series	DLT40PYIG3922	DLT40PYDI3808	DLT40MADA0002	DLT40MAHD0002	DLT40PYEU0002	DLT40PYEL0002	MS51595-61 10-24 x 3/8" Flat Socket Cap	DLT40PYHA3808
25mm		DLT40PYIG3925	DLT40PYDI3925						DLT40PYHA3925
28mm		DLT40PYIG3928	DLT40PYDI3812						DLT40PYHA3812
30mm		DLT40PYIG3930	DLT40PYDI3930						DLT40PYHA3930

\*Head Assembly Includes: Die Set, Die Block, Head, Endplates and Endplate Bolts

# PYPLOK® Tool Matrix

## DM 80 Series - Metric Tube

### Model 55 Power Unit - DLT55MAPW0000

Size	Fitting Series	Inspection Gauge	Die Set	Die Block	Head	Upper Endplates	Lower Endplates	Endplate Bolts	*Head Assembly
Model 55 - 01' Series									
22mm	DM 80 Series	DLT40PYIG3922	DLT55PYDI3808	DLT55MADA0001	DLT55MAHD0001	DLT55PYEU0001	DLT55PYEU0001	MS51595-61 10-24 x 3/8" Flat Socket Cap	DLT55PYHA3808
25mm		DLT40PYIG3925	DLT55PYDI3925						DLT55PYHA3925
28mm		DLT40PYIG3928	DLT55PYDI3812						DLT55PYHA3812
30mm		DLT40PYIG3930	DLT55PYDI3930						DLT55PYHA3930
35mm		DLT55PYIG3935	DLT55PYDI3816						DLT55PYHA3816
38mm		DLT55PYIG3938	DLT55PYDI3938						DLT55PYHA3938
42mm		DLT55PYIG3820	DLT55PYDI3820						DLT55PYHA3820
50mm		DLT55PYIG3950	DLT55PYDI3824						DLT55PYHA3824

### Model 70 Power Unit - DLT70MAPW0000

Size	Fitting Series	Inspection Gauge	Die Set	Die Block	Head	Upper Endplates	Lower Endplates	Endplate Bolts	*Head Assembly
Model 70 - 01' Series									
35mm	DM 80 Series	DLT55PYIG3935	DLT70PYDI3816	DLT70MADA0001	DLT70MAHD0001	DLT70PYEU0001	DLT70PYEL0001	MS51595-61 10-24 x 3/8" Flat Socket Cap	DLT70PYHA3816
38mm		DLT55PYIG3938	DLT70PYDI3938						DLT70PYHA3938
42mm		DLT55PYIG3820	DLT70PYDI3820						DLT70PYHA3820
50mm		DLT55PYIG3950	DLT70PYDI3824						DLT70PYHA3824
60mm		DLT70PYIG3832	DLT70PYDI3832						DLT70PYHA3832

\*Head Assembly Includes: Die Set, Die Block, Head, Endplates and Endplate Bolts

# PYPLOK® Tool Matrix

## DP 40 Series - NPS Low Pressure

Model 70 Power Unit - DLT70MAPW0000									
Size	Fitting Series	Inspection Gauge	Die Set	Die Block	Head	Upper Endplates	Lower Endplates	Endplate Bolts	*Head Assembly
Model 70 - 02' Series								MS51595-61 10-24 x 3/8" Flat Socket Cap	
2-1/2"	DP 40 Series	DLT70PYIG4040	DLT70PYDI4040	DLT70MAHD0002	DLT70MAHD0002	DLT70PYEU0002	DLT70PYEL0002		DLT70PYHA4040
3"		DLT70PYIG4048	DLT70PYDI4048						DLT70PYHA4048

Model 86 Power Unit - DLT86MAPW0000									
Size	Fitting Series	Inspection Gauge	Die Set	Die Block	Head	Upper Endplates	Lower Endplates	Endplate Bolts	*Head Assembly
Model 86 - 00' Series								1/4-28 x 1/2" Socket Cap	DLT86PYHA4064
4"	DP 40 Series	DLT86PYIG4064	DLT86PYDI4064	DLT86MADA0000	DLT86MAHD0000	DLT86PYEP0001	DLT86PYEP0001		

\*Head Assembly Includes: Die Set, Die Block, Head, Endplates and Endplate Bolts

## DP 04 Series - Metric Pipe CuNi

Model 55 Power Unit - DLT55MAPW0000									
Size	Fitting Series	Inspection Gauge	Die Set	Die Block	Head	Upper Endplates	Lower Endplates	Endplate Bolts	*Head Assembly
Model 55 - 01' Series								MS51595-61 10-24 x 3/8" Flat Socket Cap	
44.5mm	DP 04 Series	DLT55PYIG4244	DLT55PYDI3944	DLT55MADA0001	DLT55MAHD0001	DLT55PYEU0001	DLT55PYEL0001		DLT55PYHA3944
57mm		DLT55PYIG4257	DLT55PYDI3957						DLT55PYHA3957

\*Head Assembly Includes: Die Set, Die Block, Head, Endplates and Endplate Bolts

# Tube and Pipe Qualification

DM 20 Series - NPS Pipe		
Size	Min. Wall	Max. Wall
1/4"	Sch.10	Sch.80
3/8"	Sch.10	Sch.80
1/2"	Sch.10	Sch.80
3/4"	Sch.10	Sch.80
1"	Sch.10	Sch.160
1-1/4"	Sch.10	Sch.160
1-1/2"	Sch.10	Sch.160
2"	Sch.10	Sch.160
3"	Sch.80	Sch.160

DM 60 Series - OD Tube		
Size	Min. Wall	Max. Wall
1/4"	0.028"	0.083"
3/8"	0.028"	0.095"
1/2"	0.035"	0.120"
5/8"	0.035"	0.120"
3/4"	0.049"	0.180"
1"	0.049"	0.180"
1-1/4"	0.065"	0.220"
1-1/2"	0.065"	0.220"
2"	0.065"	0.220"

DM 80 Series - Metric Tube		
Size	Min. Wall	Max. Wall
6mm	1mm	2mm
8mm	1mm	2mm
10mm	1mm	3mm
12mm	1mm	3mm
15mm	1mm	3mm
16mm	1mm	3mm
18mm	1mm	3mm
20mm	1mm	4mm
22mm	1mm	4mm
25mm	2mm	4mm
28mm	2mm	4mm
30mm	2mm	4mm
35mm	2mm	4mm
38mm	3mm	5mm
42mm	3mm	5mm
50mm	3mm	5mm
60mm	3mm	8mm

DP 40 Series - NPS Low Pressure		
Size	Min. Wall	Max. Wall
2-1/2"	Sch.10	Sch.80
3"	Sch.10	Sch.80
4"	Sch.10	Sch.80

DP 04 Series - Metric Pipe CuNi Tube		
Size	Min. Wall	Max. Wall
44.5mm	1mm	3mm
57mm	1mm	3mm
76mm	1mm	3mm

Allowable Outside Pipe/Tube Diameter Tolerances for PYPLOK®		
NPS Pipe	1/4" to 1-1/2"	+/- 0.015" (0.381mm)
	2" - 4"	+/- 0.030" (0.762mm)
OD Tube	1/4" to 3/8"	+/- 0.005" (0.127mm)
	1/2" to 1-1/2"	+/- 0.010" (0.254mm)
	2"	+/- 0.015" (0.381mm)
Metric Tube	6mm to 38mm	+/- 0.254mm (0.010")
	42mm to 60mm	+/- 0.381mm (0.015")

*Qualified Pipe/Tube		
Stainless Steel PYPLOK®	Carbon Steel PYPLOK®	Copper Nickel PYPLOK®
ASTM A312/A269 (304/304L/316/316L) EN 10216-5 (304/304L/316/316L) EN10305-4 (E355N/ST52.4)	ASTM A106 Gr. A/B/C A53 ERW Gr. A/B EN10305-4 (E355N/E235N/ST52.4/ST37.4) API 5L Seamless/ERW ASTM A333 Gr.6	MIL-T-16420 (70/30 & 90/10)

\*As there are numerous pipe/tube specs, not every spec has been listed. If you do not see your spec please consult the factory to confirm pipe/tube qualification.

**2" NPS DM 20 Series Carbon Steel PYPLOK® cannot be used on EN 10305-4 (E355N/ST52.4) pipe/tube but as replacement 2" NPS DM 20 Series Stainless Steel PYPLOK® or 60mm DM 80 Series Carbon Steel PYPLOK® can be used.**



# PYPLOK®

## GLOBAL HEADQUARTERS:

TUBE-MAC® PIPING TECHNOLOGIES LTD.  
853 Arvin Avenue  
Stoney Creek, Ontario L8E 5N8  
Canada  
Tel: +1 905-643-8823



TUBE-MAC® INDUSTRIES INC.  
420 Halstead Blvd.  
Zelienople, Pennsylvania  
USA 16063  
Tel: (724) 473-0823

TUBE-MAC® INDUSTRIES INC.  
25702 Aldine Westfield Road,  
Suite 501  
Spring, Texas  
USA 77373  
Tel: (281) 912-0521

TUBE-MAC® INDUSTRIES  
(SERVICES) INC.  
5201 Orchard Road  
Pascagoula, Mississippi  
USA 39568  
Tel: (228) 762-1732

TUBE-MAC® PIPING  
TECHNOLOGIES, S.L.  
C/ Plutón, 3  
Aulencia Industrial Park  
28229 Villanueva del Pardillo  
Madrid, Spain  
Tel: +34 91 813 5050

TUBE-MAC® DO BRASIL LTDA.  
Rio De Janeiro – RJ  
Brasil  
Tel: +55 21 3328 0559

TUBE-MAC® PIPING  
TECHNOLOGIES GMBH.  
Egon-Schiele-Str. 1  
A-4614 Marchtrenk  
Austria  
Tel: +43 (0) 7243 51200



For more information please contact  
Tube-Mac® or your local distributor



[www.pyplok.com](http://www.pyplok.com)

