



GYROLOK® XP

For Mission Critical Applications



CRANE

CRANE Instrumentation & Sampling, HOKE®
PO Box 4866 • Spartanburg, SC 29305-4866
(864) 574-7966 • www.hoke.com

GYROLOK® XP

A Technology Breakthrough in Safety and Reliability for Small Bore Tubing Systems

GYROLOK® XP has been developed as a critical service, durable design to improve safety at higher pressures and provide easier installation on small bore tubing systems.

GYROLOK® XP incorporates design and material technology innovations that allow the fitting to be assembled onto high yield strength and thicker wall tube, compared to conventional compression tube fitting designs.

GYROLOK® XP has been fully validated across a broad range of austenitic and high performance alloys, tubing sizes, and wall thicknesses.

Examples include: 316, 6MO, Super Duplex, 625/825, HC

Unique design innovations allow the fitting to be used at higher pressures on thicker walled tubing; in some cases, eliminating the need for less reliable cone and threaded arrangements or more costly welded installation or other permanent methods.



Key Product Advantages

Mechanically Stronger Fitting Nut

- 70% more material in high stress areas
- 50% more thread engagement means lower make-up torque, and greater tube holding performance

Fitting Ferrule Systems

- **Front Ferrule** - Sharper delta angle feature to improve sealing on hard / heavy wall tube
- **Rear Ferrule** - Provides better gyration control to grip tighter and more reliably on higher yield strength/tough tube, such as: Super Duplex, HC, 625.

Built in Assembly Gauge

- Exposed fitting body threads provide a visual indicator to show the fitting is not fully assembled. The assembly condition of the fitting is instantly recognizable
- Mechanical Safety stop prevents the fitting from being over tightened

Standard Features

- Standard 1 ¼ turns make up procedure
- Works with standard tubing
- Available from 6mm to 50mm / ¼" to 2" sizes
- Available in a full range of corrosion resistant alloys including 6mo, HC, Super Duplex etc.

GYROLOK® Original

GYROLOK® XP

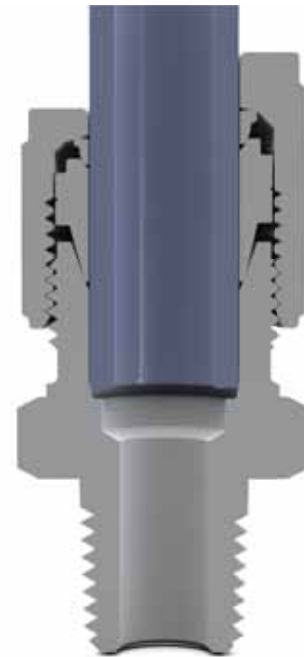

Increased Pressure Ratings

GYROLOK® XP – Pressure Rating Comparison

- > Increased pressure ratings over competitors by an average of 46%
- > Maximum allowable working pressure comparison (3X guaranteed safety factor)
- > Imperial & metric fittings

6MO GYROLOK XP VS. BRAND-X

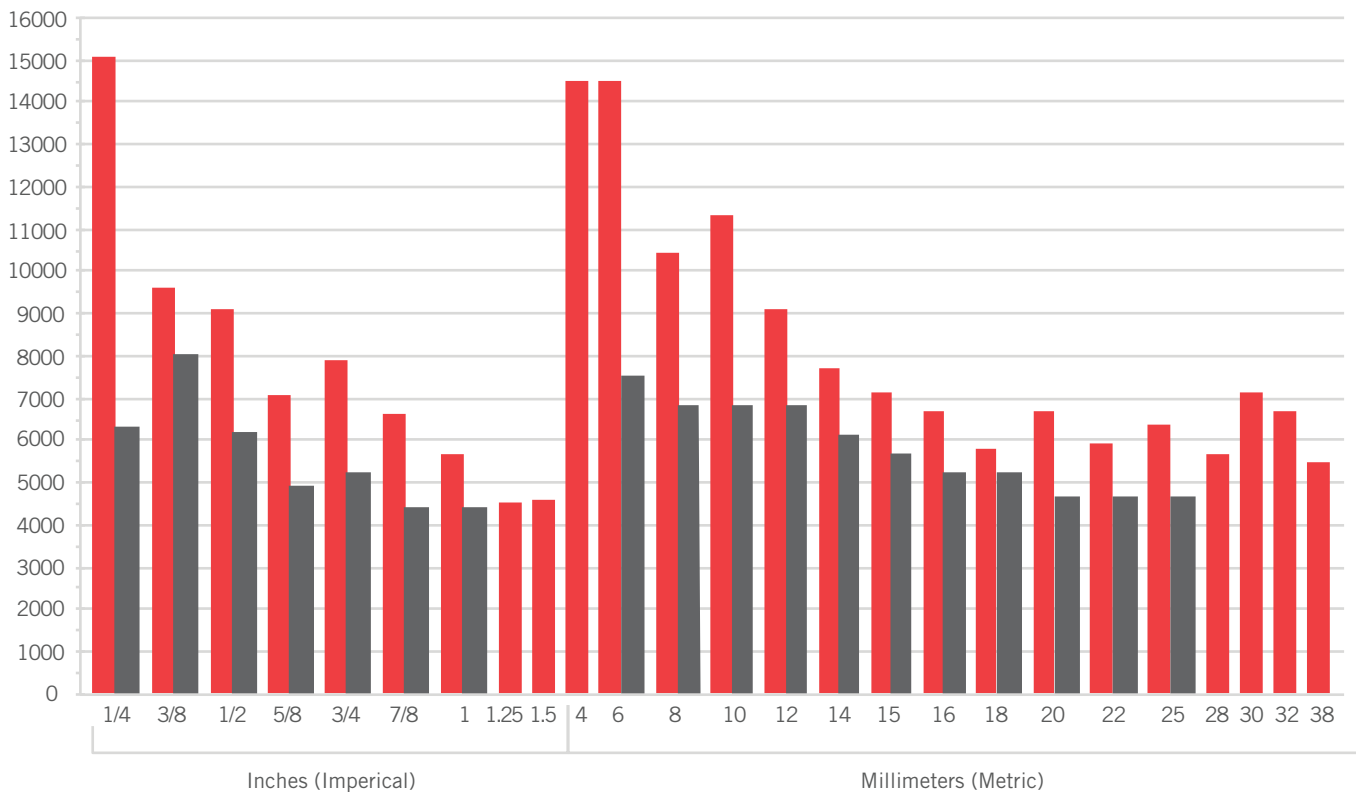

GYROLOK® XP with Enhanced Tube Gripping Technology

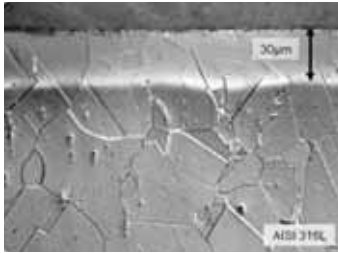

Rear ferrule is surface hardened

Rear ferrule is low temperature surface hardened using a process called Kolsterising to enhance sealing and gripping of heavy wall tube on tough corrosion resistant alloy tube. After being heat treated, the ferrule retains its full corrosion resistance capabilities, unlike some alternative heat treatments which may deplete chromium.



Rear ferrule technology bites into the tube surface

Rear ferrule technology is designed to bite through the surface of the hard micro skin of the high alloy tube. Rear ferrules bite into the tube while simultaneously forming a front ferrule seal between the tube and body.



GYROLOK® XP is designed and validated to work on standard, seamless, and welded ASTM A269 tubing, as well as tempered high strength tubing

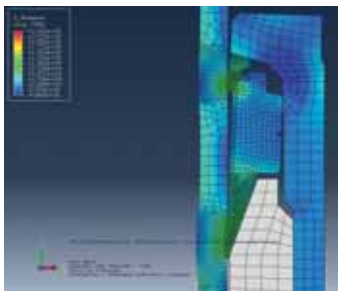

Non-linear FEA

GYROLOK® XP – Designed using advanced computational modeling methods via finite element analysis

- Faster new product development
- Reduce costs to develop new products
- Provide greater product reliability
- Improve quality
- Assist with development of testing process
- Improve the product manufacturing process
- Allow for examination of “what if” design scenarios



Full Range of High Pressure Valves with XP Connections

Full Range of Needle & Ball Valves,
Manifolds, Double block and bleed valves,
Flange Adapters, Monoflanges

10,000 psi & 15,000 psi Working Pressure

- > Meets ANSI B31.3
- > Meets MS SP 99

Connections available as

- > Gyrolok XP tube fitting
- > NPT Female
- > API 6A (Medium Pressure) cone and threaded

Materials

- > 316
- > 6MO, Super Duplex
- > 625/825
- > HC, Titanium



Key Applications

- Process Instrumentation systems
- Sub-sea & down hole applications
- Sour Gas & NACE applications
- Offshore environments with high levels of pitting corrosion
- Chemical Injection & Sampling systems
- High pressure CNG
- Hydrogen applications for alternative fuels technology
- High pressure hydraulics & Hydraulic power unit builder

Materials

- 316
- 6MO, Super Duplex
- 625/825
- HC, Titanium

GYROLOK® XP Technology has been designed with over 80 Years of experience using the latest engineering innovation, with validation through rigorous testing and field trials.

Lloyd's Register witnessed.





The Small Bore Instrumentation Specialists



We specialize in small bore instrumentation products up to 2" that deliver benchmark performance quality & safety; provide the broadest array of superior alloy offerings in the market; decades of proven success in a wide range of industries; a roster of "who's who" customers & projects globally; original "Best Solution" engineering & designs; and are focused on continuous improvement in all aspects of our business.

Proudly Distributed By:

CRANE®

CRANE INSTRUMENTATION &
SAMPLING Inc.
405 Centura Ct.
Spartanburg, SC 29305, USA
Tel: 1-864-574-7966
PO Box 4866, Spartanburg, SC
29305-4866 USA

Crane Co., and its subsidiaries cannot accept responsibility for possible errors in catalogues, brochures, other printed materials, and website information. Crane Co. reserves the right to alter its products without notice, including products already on order provided that such alteration can be made without changes being necessary in specifications already agreed. All trademarks in this material are the property of the Crane Co. or its subsidiaries. The Crane and Crane brands logotype (CENTER LINE®, COMPAC-NOZ®, CRANE®, DEPA® & ELRO®, DOPAK®, DUO-CHEK®, FLOWSEAL®, GYROLOK®, GO REGULATOR®, HOKE®, JENKINS®, KROMBACH®, NOZ-CHEK®, PACIFIC VALVES®, RESISTOFLEX®, REVO®, SAUNDERS®, STOCKHAM®, TEXAS SAMPLING®, TRIANGLE®, UNI-CHEK®, VALVES®, WTA®, and XOMOX®) are registered trademarks of Crane Co. All rights reserved.