

PROCHEM

Stainless Steel Specialists

Product solutions for a world of difference

PIPING PRODUCTS

VALVES



PIPING PRODUCTS



INSTRUMENTATION



VALVES AND ACTUATORS



MANUFACTURING



INDENT SERVICE



HYDRAULIC



STAINLESS STEEL

Ball Valves

Prochem offers a full range of high quality ball valves for a variety of general and specialty applications. Stocks are maintained at our branches Australia-wide, ensuring that our customers can rely on quick access to the most suitable style of ball valve for their needs.

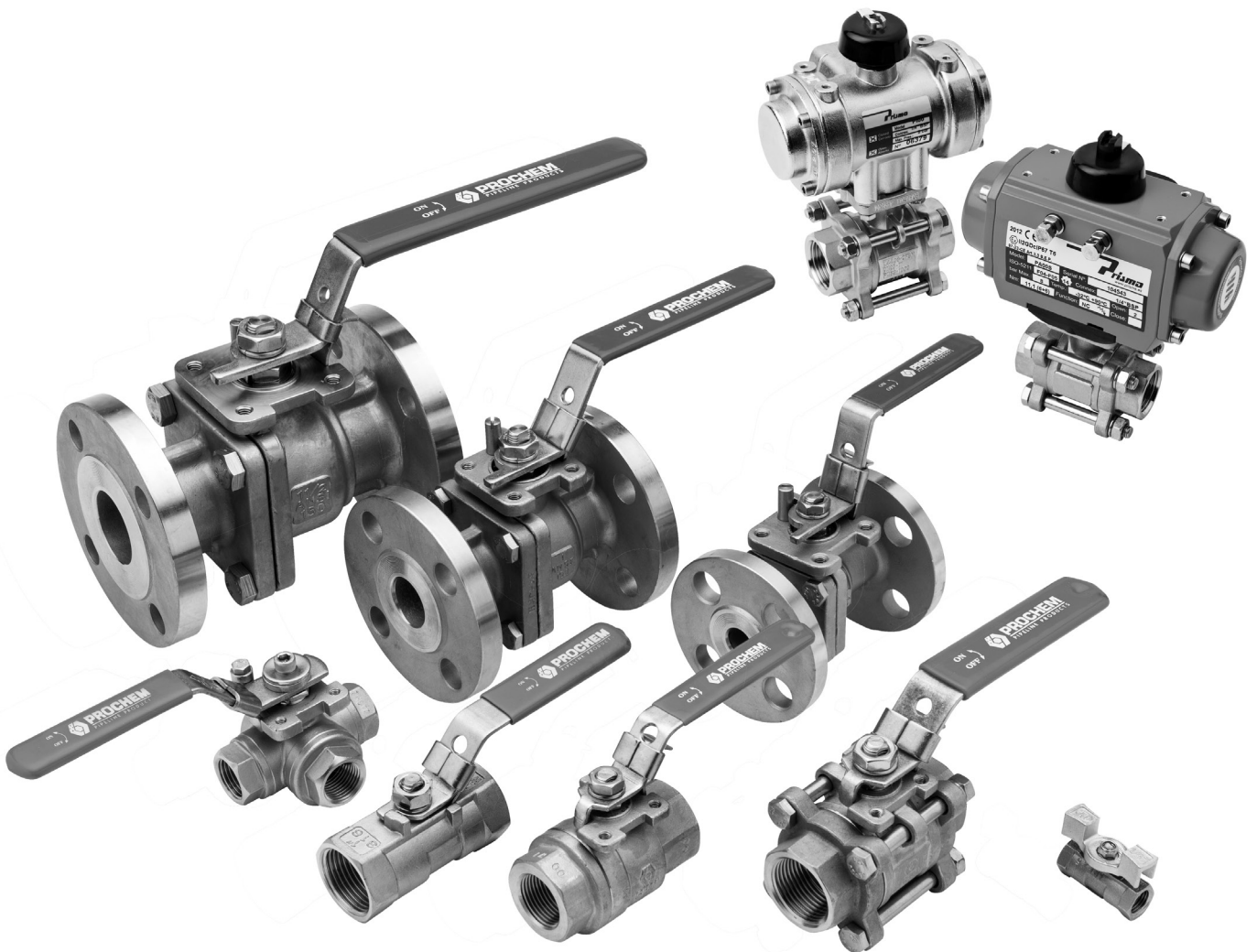



2-WAY REDUCED BORE 1-PIECE STAINLESS BSP 800 W.O.G.

These simple, practical, 1-piece “bar-stock” type valves provide the most economic solution for manual control of air, water, and other clean and corrosive fluids in many environments.

Available in sizes 8 (1/4") to 50 mm (2").

- Reduced port
- 1-piece economy design
- Investment cast CF8M
- Anti-blowout stem
- Seat material Virgin PTFE

Pressure/Temperature Rating

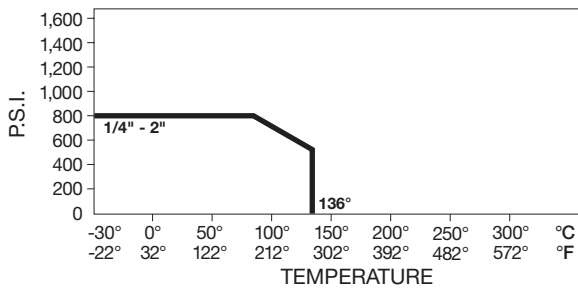

2-WAY REDUCED BORE 1-PIECE HIGH PRESSURE STAINLESS BSP W.O.G.

This valve provides the user with a higher working pressure compared to the 800 W.O.G. 1-piece “bar-stock” valves.

Available in sizes 8 (1/4") to 50 mm (2").

- Reduced port
- 1-piece economy design
- Investment cast CF8M
- Anti-blowout stem
- Seat material Virgin PTFE

Pressure/Temperature Rating

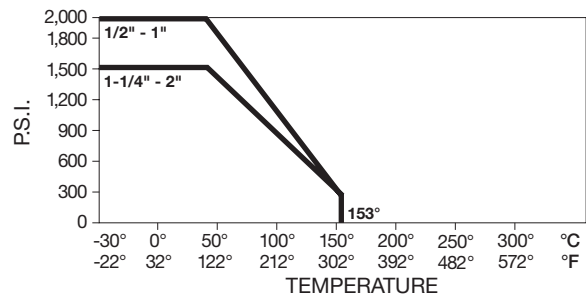



2-WAY FULL BORE 2-PIECE STAINLESS BSP W.O.G.

Full bore 2-piece threaded valves allowing straight-through flow. Virtually no head loss and a superior performer with mildly abrasive as well as corrosive fluids. Ideal for in-line control of process fluids.

Available in sizes 8 (1/4") to 80 mm (3").

- Full port
- 2-piece body
- Investment cast CF8M
- Anti-blowout stem
- Adjustable stem packing
- Actuator mounting pad to ISO 5211
- Seat material Virgin PTFE

Pressure/Temperature Rating

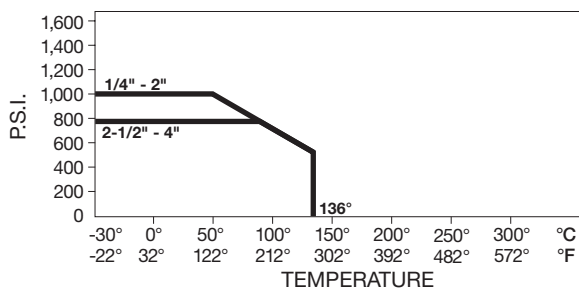

Size		Torque		Weight kgs
mm	in	Nm	in/lbs	
8	1/4	5.8	50	.23
10	3/8	5.8	50	.23
15	1/2	8.5	75	.31
20	3/4	11.3	100	.57
25	1	20.5	180	.91
32	1-1/4	27	235	1.5
40	1-1/2	34	300	2.0
50	2	37.3	330	3.5



2-WAY FULL BORE 3-PIECE STAINLESS BSP AND NPT W.O.G.

3-piece construction allows end connections to be permanently fitted to the pipe, so the valve body can be removed enabling replacement of seals without disturbing pipework.

Available in sizes 8 (1/4") to 100 mm (4").

- Full port
- 3-piece swing out body
- Investment cast CF8M
- In-line repairable
- Anti-blowout stem
- Locking SS handle
- Adjustable stem packing
- Actuator mounting pad to ISO 5211
- Seat material Reinforced PTFE

Pressure/Temperature Rating

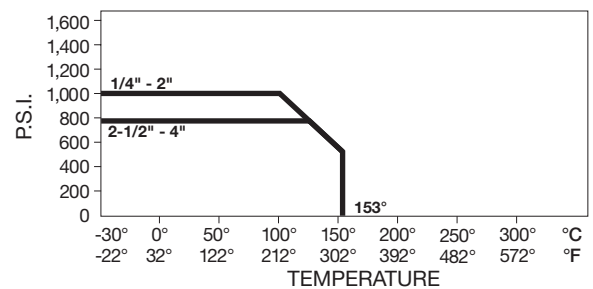

Size		Torque		Weight kgs
mm	in	Nm	in/lbs	
8	1/4	5.8	50	.45
10	3/8	5.8	50	.45
15	1/2	7.5	65	.45
20	3/4	10	80	.91
25	1	17	150	1.4
32	1-1/4	23	200	2.0
40	1-1/2	25.5	225	2.4
50	2	28.5	250	3.6
65	2-1/2	96	850	9.1
80	3	113	1000	12.7
100	4	272	2400	20.4



**3-WAY REDUCED BORE
STAINLESS BSP 800 W.O.G.**

L-ported valves available to replace two normal valves, saving space, cost and weight.

Available in sizes 8 (1/4") to 50 mm (2").

"T" Ported valves available on request.

- Reduced port
- Investment cast CF8M
- Anti-blowout stem
- Actuator mounting pad
- Seat material Virgin PTFE

Pressure/Temperature Rating

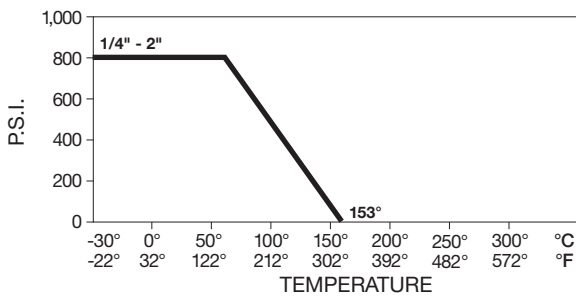

**2-WAY FULL BORE 2-PIECE
STAINLESS NPT W.O.G.**

Full Bore 2-piece threaded valves allowing straight-through flow. Virtually no head loss and a superior performer with mildly abrasive as well as corrosive fluids. Ideal for in-line control of process fluids.

Available in sizes 8 (1/4") to 50 mm (2").

- **All 316 wetted and non wetted components**
- Full Port
- 2-piece body
- Investment cast CF8M
- Anti-blowout stem
- Adjustable stem packing
- Actuator mounting pad to ISO 5211
- Seat material Virgin PTFE

Pressure/Temperature Rating

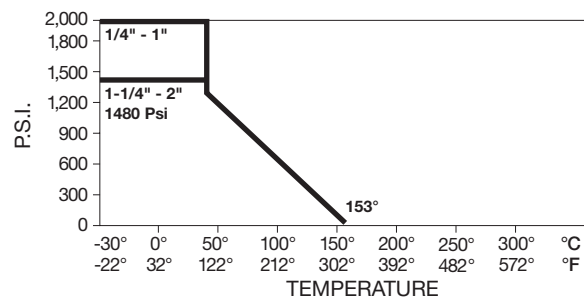

Flanged Ball Valves

Split Body ANSI-ISO stainless steel flanged ball valves

- Full bore for minimum pressure drop
- In-line repairable split body design
- Investment cast through 100 mm (4") – CF8M
- Anti-blowout stem
- Adjustable stem packing
- Locking handle
- Static grounding device
- Flange dimensions to ANSI B16.5 and AS 2129
- Face to face dimension to ANSI B16.10
- Design in accordance ANSI B16.34 and API60 Testing to API 598
- Actuator mounting pad to ISO 5211
- Vacuum service down to 20 microns
- Stocked in ANSI Class 150, Table D and E

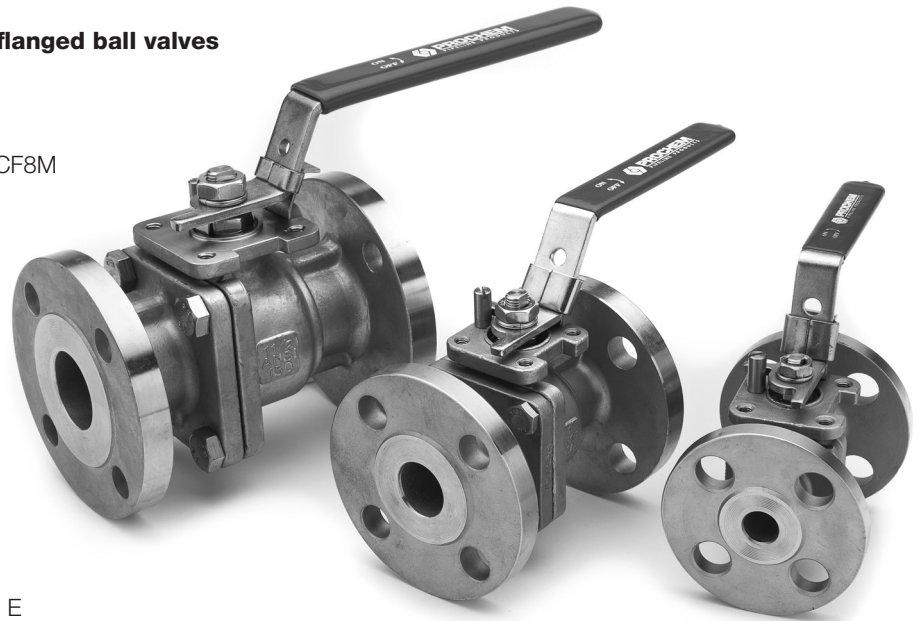

CLASS 150* (all dimensions are in millimetres)														
Size		A	B	C	D	E	F	L	I	N	K	W	U	J
mm	inch													
15	1/2"	1.6	11.2	9.6	15	60.5	88.9	108	16	4	120	91.0	50	M6
20	3/4"	1.6	12.7	11.1	20	69.9	98.6	117	16	4	120	94.5	50	M6
25	1"	1.6	14.3	12.7	25	79.3	108.0	127	16	4	158	96.5	50	M6
40	1-1/2"	1.6	17.6	16.0	38	98.6	127.0	165	16	4	228	113.0	70	M8
50	2"	1.6	19.1	17.5	50	120.7	152.4	178	19	4	228	122.5	70	M8
65	2-1/2"	1.6	22.4	20.8	65	139.8	178.0	190	19	4	349	-	102	M10
80	3"	1.6	23.9	22.3	80	152.5	190.0	203	19	4	349	-	102	M10
100	4"	1.6	23.9	22.3	100	190.5	229.0	228	19	8	349	-	102	M10

Valve Size		Breakaway Torque Nm	Weight kg
mm	inch		
15	1/2"	7-8	2.3
20	3/4"	10-11	2.7
25	1"	25-27	3.6
40	1-1/2"	42-44	6.8
50	2"	47-49	10.4
65	2-1/2"	49-52	15.9
80	3"	128-147	19.1
100	4"	156-168	29.9

* Refer to AS 2129 for table flange dimensions

Body: ASTM-A351-CF8M
 Ball material: 316 S/S
 Seat material: Reinforced PTFE
 Stem: 316 S/S

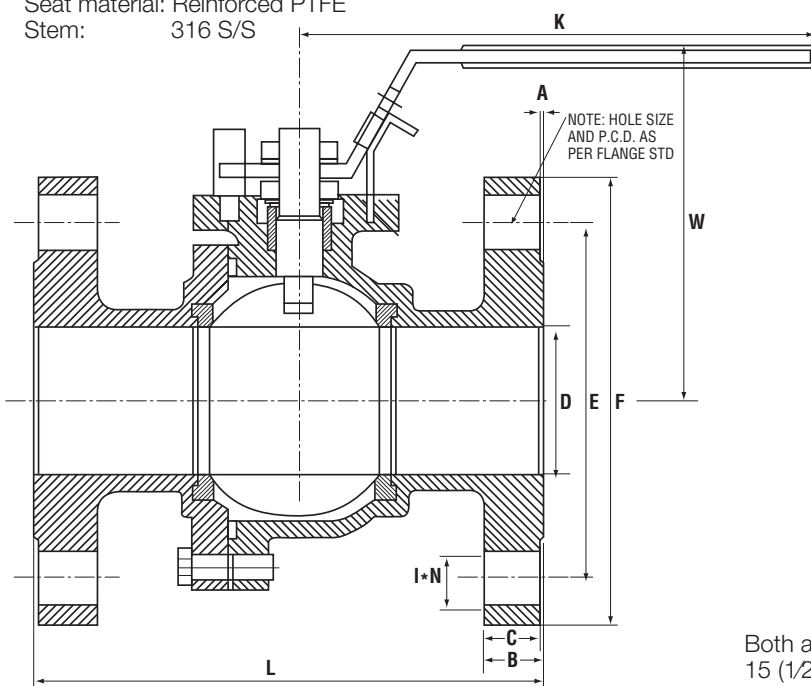

CLASS 150

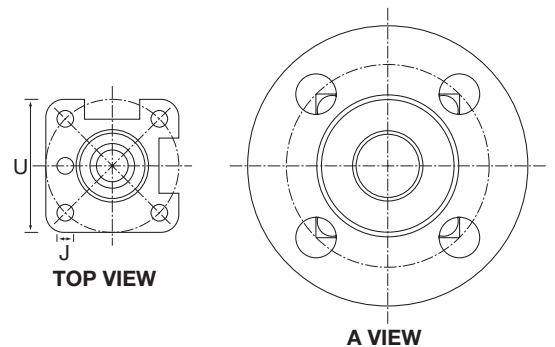
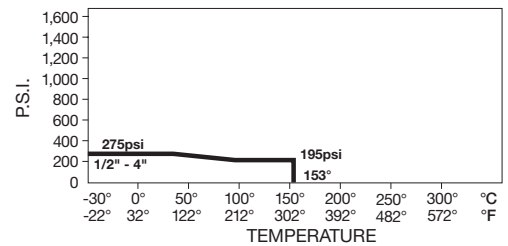

Both above views are for sizes 15 (1/2"), 20 (3/4"), 25 (1"), 40 (1-1/2") and 50 (2") valves.

Actuated Ball Valves

Prochem offers a close-fitted range of Pneumatic Double Acting and Spring Return Actuators. Anodised/ epoxy coated Aluminium alloy compact double piston and rack design, and featuring NAMUR standard ports for flush mounting of solenoid valves. Also available on request – Stainless Steel Actuators.

Standard compact mounting kits are generally common for either double acting or spring return actuators on the same valve.

Suitable for the Prochem range of 2-piece full bore threaded valves – 3-piece full bore threaded valves – 2-piece full bore flanged valves.

Refer to the Matching Chart below to select the actuator to suit your valves.

GENERAL FEATURES

- Air supply: filtered, dry or lubricated, pressure minimum 1 bar (14 psi), pressure maximum 10 bar (142 psi).
- Lubrication: factory lubricated, guaranteed for 500,000 strokes minimum.
- Internal sliding surface lapped and anodized (Ra 0.8 – 1-2 µm on cut off 12.5 mm), for minimum friction and very long life to actuator.
- Guide bearings made by low friction material, to avoid metal to metal contact, easily replaceable for maintenance.
- Double bottom drilling, for actuator to valve assembling and centering as ISO 5211/DIN 3337 standard.
- Bottom shaft female key, as ISO 5211/DIN 3337 standard, double square hole for assembling on valves with square key stem in line or turned 45°.
- Air supply ports drilling as NAMUR standard or with interface plate as NAMUR standard.
- Top drilling for accessories assembling and shaft top end as NAMUR standard.
- Position indicator on request.

- Standard temperature range: -20 to 90°C (-4 to 194°F). Special (on request) range: -40 to 160°C (-40 to 320°F).
- External protection: corrosion as ASTM B 117-73.
- Each actuator is branded with a progressive serial number for easy identification and traceability.
- All actuators are cycle and pressure tested.

MANUFACTURING MATERIALS

Body: Extruded Aluminium alloy ASTM 6063, anodised UNI 4522 (Epoxy coated).

Caps: Die-cast Aluminium alloy UNI 5076, powder epoxy coated.

Pistons: Die-cast Aluminium alloy UNI 5076

Shaft: Steel AISI SAE 11L37, Electroless nickel plated ASTM B 656.

Guides: Low friction acetalic resin.

Bolts: Stainless steel AISI 304.

Springs: Preloaded spring cartridges, patented all around the world since 1986, powder epoxy coated.

Sealing: Nitrilic rubber BUNA N (on request VITON or EPDM).

DOUBLE ACTING ACTUATORS (TOP VIEW)

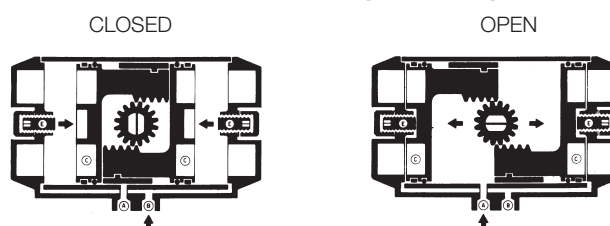

SPRING RETURN ACTUATORS (TOP VIEW)

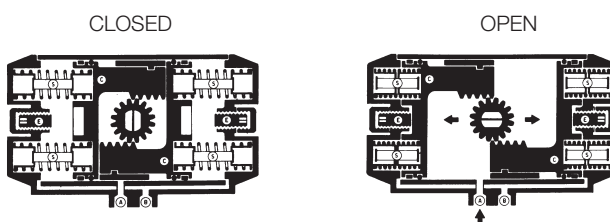

MATCHING CHART: ACTUATOR TO VALVE SIZE AND TYPE (spring return actuators available on request)

Prochem Two Piece Full Bore Stainless Ball Valve		Double Acting Actuator	Prochem Three Piece Full Bore Stainless Ball Valve		Double Acting Actuator	Prochem Two Piece Flanged Full Bore Stainless Ball Valve		Double Acting Actuator
metric	inches	model #	metric	inches	model #	metric	inches	model #
8	1/4	X 52	8	1/4	X 52	15	1/2	X 52
10	3/8	X 52	10	3/8	X 52	20	3/4	X 52
15	1/2	X 52	15	1/2	X 52	25	1	X 52
20	3/4	X 52	20	3/4	X 63	40	1-1/2	X 63
25	1	X 63	25	1	X 63	50	2	X 75
32	1-1/4	X 75	32	1-1/4	X 63	65	2-1/2	X 75
40	1-1/2	X 75	40	1-1/2	X 75	80	3	X 83
50	2	X 75	50	2	X 110	100	4	X 110
			65	2-1/2	X 110	150	6	
			80	3	X 160	200	8	
			100	4				

Swing Check Valve



Swing Check Valves – BSP, Class 200 W.O.G.

- Horizontal and Vertical Swing type
- Investment cast CF8M
- Screwed Cover
- Sizes 8 (1/4") to 50 mm (2")

**PRESSURE TEMPERATURE RATING
SWING CHECK CLASS 200**

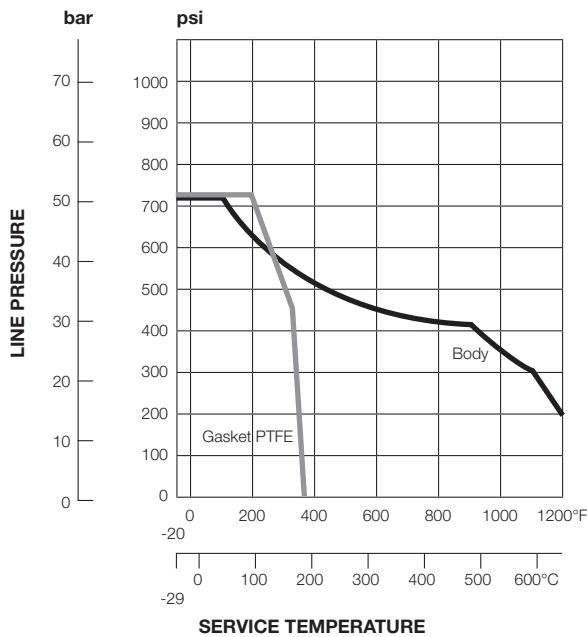

Y-Type Strainer



Y-Type Strainers

- Investment cast CF8M
- Screwed Cover and Plug
- Removable Filter
- Perforations 1 mm x 2 mm centres
- Sizes 15 (1/2") to 50 mm (2")

**PRESSURE TEMPERATURE RATING
Y STRAINER**

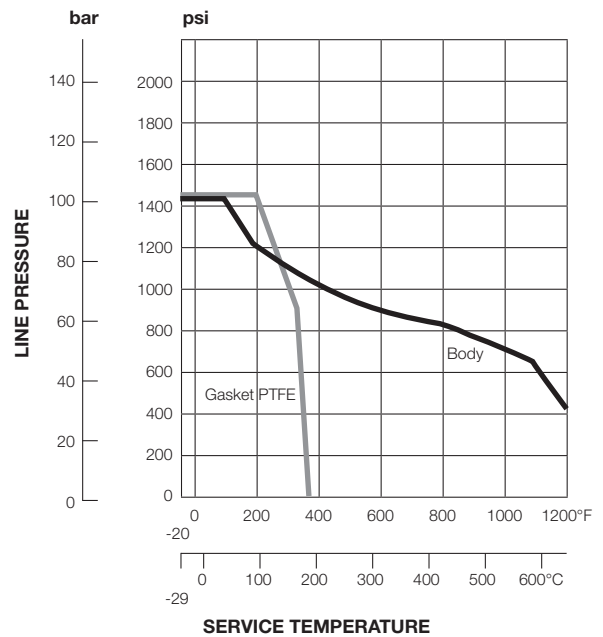

Spring Check Valve



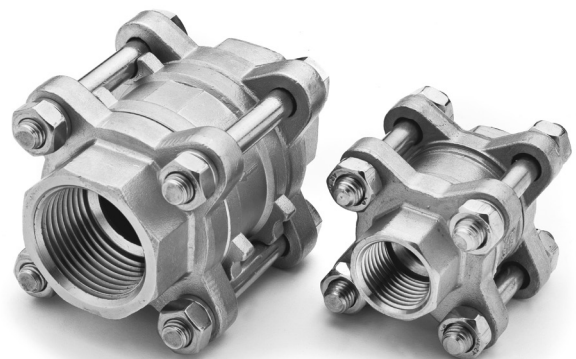

Spring Check Valves – BSP, 1000 W.O.G.

- 3 Piece
- Investment cast CF8M Body and End Cap
- T-316 Disc
- Sizes 8 to 100 mm (4")



STAINLESS STEEL
FLANGES
FITTINGS
PIPE
TUBE
VALVES
PYPLOK
FITTINGS
TWT
TUBE-MAG
PIPING TECHNOLOGIES

GYROLOK[®]
 **CIRCLE SEAL CONTROLS**
HOKE
GO REGULATOR
 **ANDERSON GREENWOOD**
INSTRUMENT TUBE
Classic FILTERS
CIRCOR
INSTRUMENTATION TECHNOLOGIES
 **BuTech**
MILTON ROY
KING

 **AMPO**
POYAM VALVES
 **BSM**[®]
ATC
ACTUATOR TECHNOLOGY COMPANY
PACSON valves
 **ANDERSON GREENWOOD**
 **HABONIM**
Industrial Valves & Actuators



FOR FURTHER DETAILS PLEASE CONTACT YOUR LOCAL PROCHEM OFFICE

ADELAIDE

91 Ormond Street
Hindmarsh, South Australia
Australia 5007
Telephone 61-8-8241 7633
Facsimile 61-8-8241 7644
Email adesales@prochem.com.au

BRISBANE

63 Radley Street
Virginia, Queensland
Australia 4014
Telephone 61-7-3265 2711
Facsimile 61-7-3265 7430
Email brisales@prochem.com.au

HOBART

96-98 Central Avenue
Derwent Park, Tasmania
Australia 7009
Telephone 61-3-6272 8828
Facsimile 61-3-6272 8688
Email hobsales@prochem.com.au

MELBOURNE

5-15 Ventura Place
Dandenong South, Victoria
Australia 3175
Telephone 61-3-9799 2244
Facsimile 61-3-9799 2255
Email melsales@prochem.com.au

PERTH

6 Forge Street
Welshpool, Western Australia
Australia 6106
Telephone 61-8-9458 7777
Facsimile 61-8-9351 8170
Email persales@prochem.com.au

SYDNEY

27 Lisbon Street
Villawood, New South Wales
Australia 2163
Telephone 61-2-9727 0044
Facsimile 61-2-9728 6766
Email sydsales@prochem.com.au

SINGAPORE

69 Joo Koon Circle,
Singapore 629084
Telephone 65-6298 7887
Facsimile 65-6298 7667
Email sales@prochem.com.sg

THAILAND

5/8 Moo 4, Soi Ramintra 15,
Ramintra Road, Anusaowaree,
Bangkhen, Bangkok 10220
Telephone 66-2-970-6574
Ext 404-8
Facsimile 66-2-970-5668
Email sales@prochemthai.co.th

www.prochem.com.au