

Anderson Greenwood offer the complete range of instrument valve product.

Anderson Greenwood supply the ideal valve for each application, be it simple isolation or manifolds for pressure, flow and level measurement instruments.

In addition to its comprehensive range of standard valves and manifolds, Anderson Greenwood has also developed a number of products for primary isolation applications.

Keyblok double block and bleed integral manifolds, Anderson Greenwood has overcome the weight and space restrictions associated with many of these traditional installations compared with traditional piping valves.

Continuing along the line of meeting space savings, the Monoflange manifold is designed to mount directly to process flanges, providing maximum safety and minimum vibration. The Monoflange also combines compactness with easy access in the field since its versatile design allows for horizontal or vertical mounting.

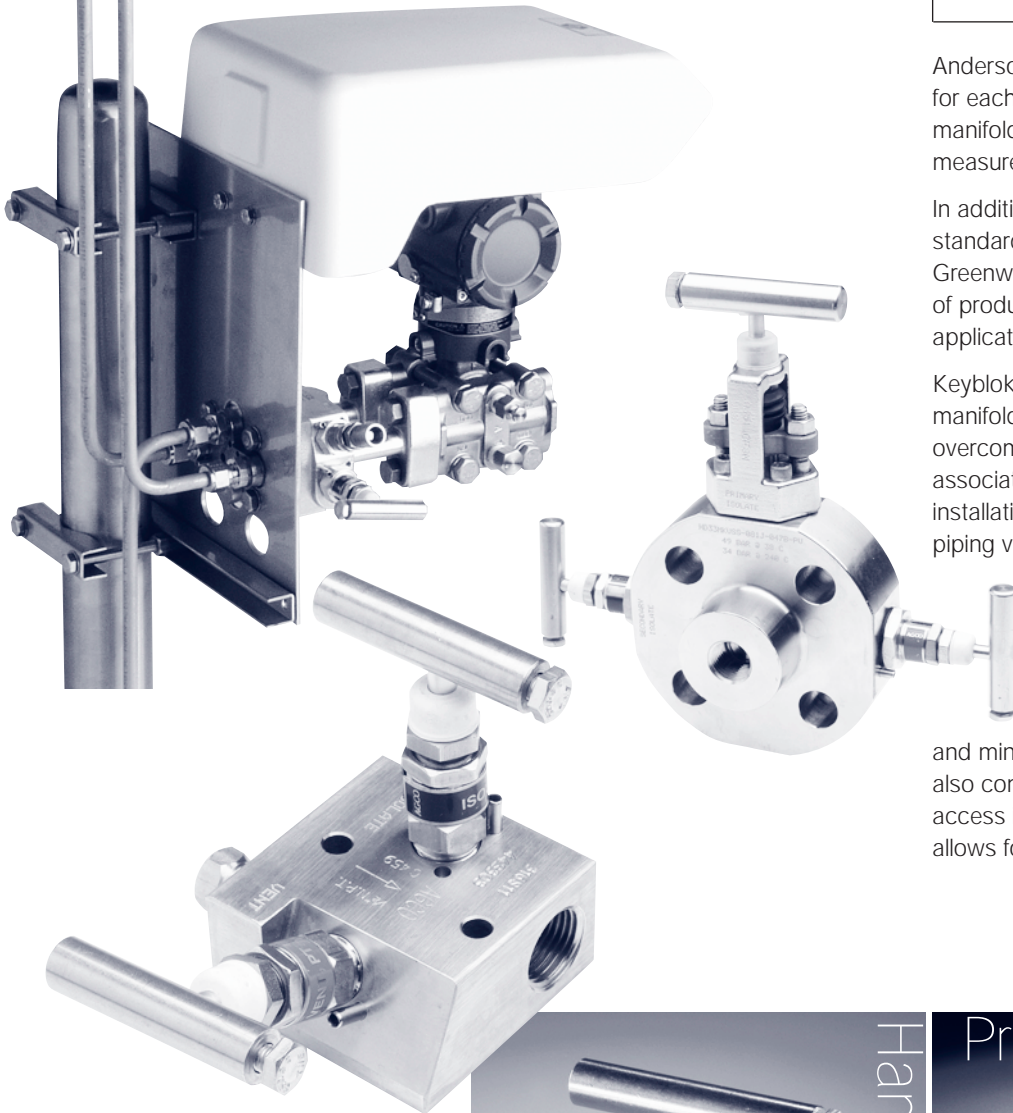

Anderson Greenwood hand valve and gauge valves include multi-port and block and bleed styles suitable for gauge isolation, calibration and venting with a choice of either globe pattern or through-bore designs. A wide choice of end connections and comprehensive range of standard gauge accessories allows complete flexibility for individual installations.

Specifications

- Materials: CS, SS, Duplex and other exotic materials
- Seats: Metal (globe and plug)
- Soft (globe and plug)
- Orrifice Size: 1/8 inch (3mm) to 5/8 inch (16mm).
- Pressure (max): 10,000 psig [690 barg]
- Temperature (max): 1,000°F [538°C]



Hand Valve



Pressure Manifold



Multi-Port Gauge



Rising Plug

Anderson Greenwood

Distribution Manifold

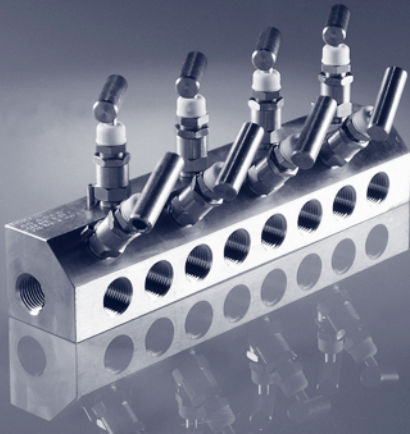

Distribution Manifolds designed to distribute air for panel and cabinet instrumentation and can easily be wall or pipestand mounted.

This distribution manifold is manufactured from barstock material in stainless steel and is available with needle valves with hard seats. Valves are suitable for pressures to 6000 psig [414 bard].

The manifold body has 1/2 inch to 1 inch NPT end connections and 1/4, 3/8 inch and 1/2 inch NPT side outlets.

Available with any of number of bonnet/outlet connections to 12 way. Outlets are equally spaced.

Manifold Valves

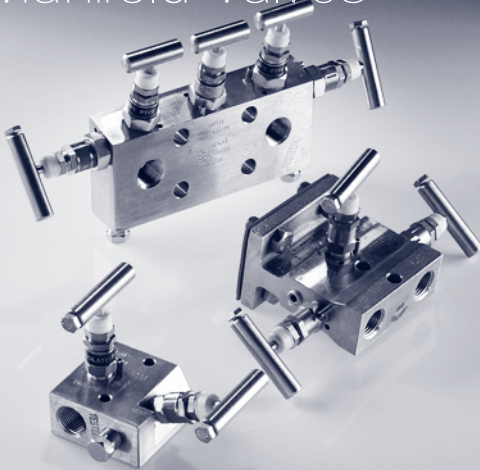

Anderson Greenwood has the largest and most innovative range of 'differential pressure' flow manifolds available in the world with models available for every kind of D/P instrument. These include conventional three and five valve manifolds as well as purpose designed models for special applications.

The range of pressure manifolds is suitable for all types of static pressure instruments from gauges to 'smart' pressure transmitters. Available for direct or remote mounting, the pressure manifolds enable isolation, calibration and venting in a single unit.

Integral manifolds are those uniquely connected to the transmitter of a specific manufacturer's model and cannot be used on a different transmitter brand. This section is presently characterized by manifolds designed specifically for Rosemount® Transmitter Models 3051, 2024 and 3095.

SaddleMount

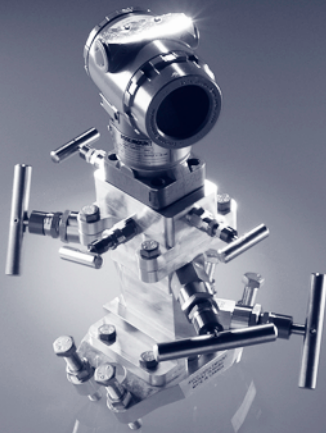

The SaddleMount™ system is designed for close coupling DP transmitters to orifice flange unions. The system can be used on DP measurement for gas, liquids and steam. The SaddleMount™ is totally self draining and can be mounted horizontally or vertically. The system features a straight-through 3/8 inch [10mm] bore directly from the orifice taps to the transmitter sensing module which reduces pulsation induced error. Pulsation error is one of the leading causes of inaccurate transmitter measurement. The system allows mounting of traditional DP or co-planer style (Rosemount 3051) DP transmitters with a choice of 3 or 5 valve instrument manifolds for power, process or natural gas measurement. The system does not require impulse lines, thereby considerably reducing installation and maintenance costs.

Modular Mounting System

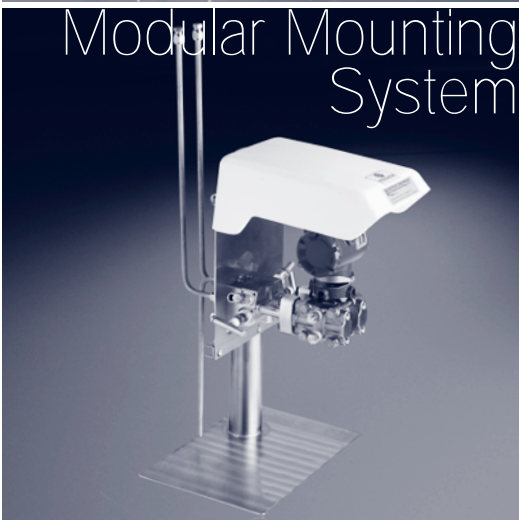

The Modular Mounting System for instrument impulse line installations has been developed in conjunction with Shell International (SIPM) and has particular applications in the petrochemical and refining industries. Based on a standard mounting plate, it allows components to be either pre-assembled in the workshop or assembled at a later stage, providing maximum flexibility without compromising quality and safety.

The Modular Mounting System has a full range of manifolds for differential pressure, pressure and gauge applications and accessories including GRP enclosures, heating blocks, seal pots, purge blocks and test connection boxes.