

PYPLOK® Tooling

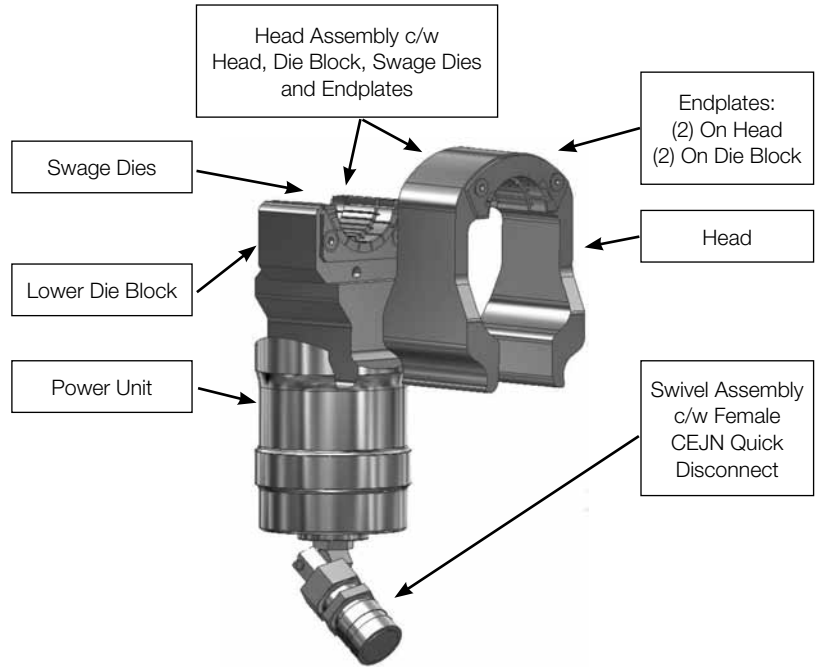

Tooling Dimensions

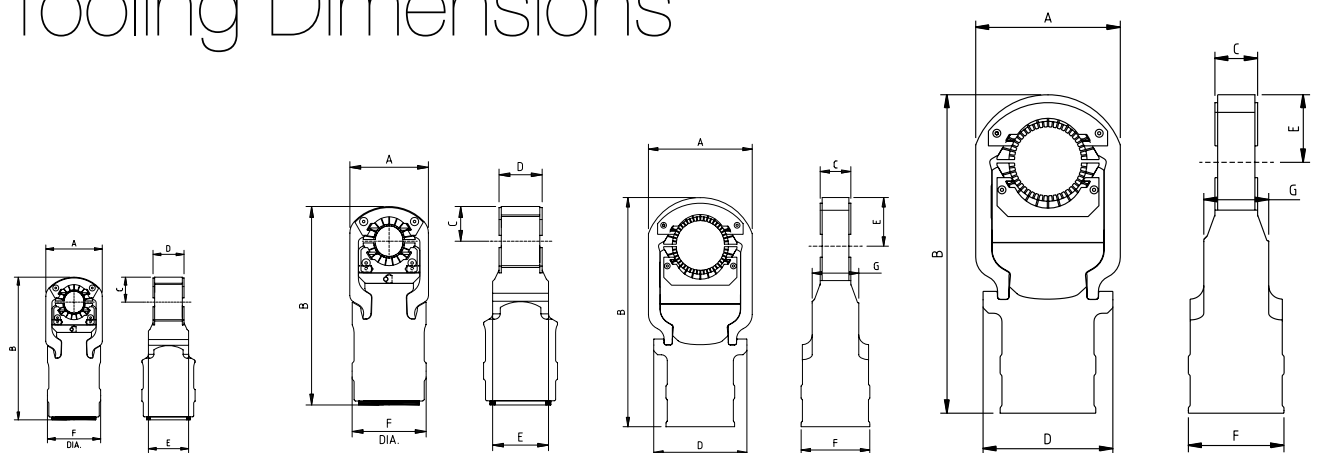

MODEL 10

| | Head Series |
|---|-------------|
| | 01 |
| A | 34 |
| B | 11 |
| C | 16 |
| D | 24 |
| E | 33 |
| F | 41 |

MODEL 40

| | Head Series | |
|---|-------------|-----------|
| | 00 | 02 |
| A | 84 | 89 |
| B | 214 | 224 |
| C | 35 | 141 |
| D | 34 | 49 |
| E | 64 | 63 |
| F | 84 | 84 |

MODEL 55

| | Head Series |
|---|-------------|
| | 01 |
| A | 132 |
| B | 252 |
| C | 49 |
| D | 152 |
| E | 94 |
| F | 105 |
| G | 76 |

MODEL 70

| | Head Series | |
|---|-------------|-----------|
| | 01 | 02 |
| A | 170 | 192 |
| B | 372 | 386 |
| C | 43 | 51 |
| D | 150 | 150 |
| E | 77 | 77 |
| F | 112 | 112 |
| G | 76 | 76 |

ALL DIMENSIONS IN MM

SEE PAGES 22 - 25 FOR CORRECT HEAD SERIES SELECTION.

NB PIPE – DM 20 / DP 40 SERIES – TOOL PARTS MATRIX (NEW GENERATION TOOL)

*Head Assembly Includes: Die Set, Die Block, Head, Endplates and Endplate Bolts

MODEL 40 POWER UNIT – DLT40MAPW0000

| Size | Fitting Series | Inspection Gauge | Die Set | Die Block | Head | Upper Endplates | Lower Endplates | Endplate Bolts | Head Assembly* |
|------------------------------|---------------------------------|------------------|---------------|---------------|---------------|-----------------|-----------------|---|----------------|
| MODEL 40 - 00' SERIES | | | | | | | | | |
| 1/4" | DM 20 Series NB Pipe | DLT40PYIG3804 | DLT40PYD13804 | DLT40MADA0000 | DLT40MAHD0000 | DLT40PYEU0000 | DLT40PYEL0000 | MS51595-61 10-24 x 3/8" Flat Socket Cap | DLT40PYHA3804 |
| 3/8" | | DLT40PYIG3806 | DLT40PYD13806 | | | | | | DLT40PYHA3806 |
| MODEL 40 - 02' SERIES | | | | | | | | | |
| 1/2" | DM 20 Series NB Pipe | DLT40PYIG3808 | DLT40PYD13808 | DLT40MADA0002 | DLT40MAHD0002 | DLT40PYEU0002 | DLT40PYEL0002 | MS51595-61 10-24 x 3/8" Flat Socket Cap | DLT40PYHA3808 |
| 3/4" | | DLT40PYIG3812 | DLT40PYD13812 | | | | | | DLT40PYHA3812 |

MODEL 55 POWER UNIT - DLT55MAPW0000

| Size | Fitting Series | Inspection Gauge | Die Set | Die Block | Head | Upper Endplates | Lower Endplates | Endplate Bolts | Head Assembly* |
|------------------------------|---------------------------------|------------------|---------------|---------------|---------------|-----------------|-----------------|---|----------------|
| MODEL 40 - 00' SERIES | | | | | | | | | |
| 1/2" | | DLT40PYIG3808 | DLT55PYD13808 | | | | | | DLT55PYHA3808 |
| 3/4" | | DLT40PYIG3812 | DLT55PYD13812 | | | | | | DLT55PYHA3812 |
| 1" | DM 20 Series NB Pipe | DLT55PYIG3816 | DLT55PYD13816 | DLT55MADA0001 | DLT55MAHD0001 | DLT55PYEU0001 | DLT55PYEL0001 | MS51595-61 10-24 x 3/8" Flat Socket Cap | DLT55PYHA3816 |
| 1-1/4" | | DLT55PYIG3820 | DLT55PYD13820 | | | | | | DLT55PYHA3820 |
| 1-1/2" | | DLT55PYIG3824 | DLT55PYD13824 | | | | | | DLT55PYHA3824 |

MODEL 70 POWER UNIT - DLT70MAPW0000

| Size | Fitting Series | Inspection Gauge | Die Set | Die Block | Head | Upper Endplates | Lower Endplates | Endplate Bolts | Head Assembly* |
|------------------------------|--|------------------|---------------|---------------|---------------|-----------------|-----------------|---|----------------|
| MODEL 70 - 01' SERIES | | | | | | | | | |
| 1" | DM 20 Series NB Pipe | DLT55PYIG3816 | DLT70PYD13816 | DLT70MADA0001 | DLT70MAHD0001 | DLT70PYEU0001 | DLT70PYEL0001 | MS51595-61 10-24 x 3/8" Flat Socket Cap | DLT70PYHA3816 |
| 1-1/4" | | DLT55PYIG3820 | DLT70PYD13820 | | | | | | DLT70PYHA3820 |
| 1-1/2" | | DLT55PYIG3824 | DLT70PYD13824 | | | | | | DLT70PYHA3824 |
| 2" | | DLT70PYIG3832 | DLT70PYD13832 | | | | | | DLT70PYHA3832 |
| MODEL 70 - 02' SERIES | | | | | | | | | |
| 2-1/2" | DP 40 Series Low Pressure NB Pipe | DLT70PYIG4040 | DLT70PYD14040 | DLT70MADA0002 | DLT70MAHD0002 | DLT70PYEU0002 | DLT70PYEL0002 | MS51595-61 10-24 x 3/8" Flat Socket Cap | DLT70PYHA4040 |
| 3" | | DLT70PYIG4048 | DLT70PYD14048 | | | | | | DLT70PYHA4048 |

OD TUBE – DM 60 SERIES – TOOL PARTS MATRIX (NEW GENERATION TOOL)

*Head Assembly Includes: Die Set, Die Block, Head, Endplates and Endplate Bolts

MODEL 10 POWER UNIT - DLT10MAPW0000

| Size | | Fitting Series | Inspection Gauge | Die Set | Die Block | Head | Upper Inboard | Lower Outboard | Lower Inboard | Lower Outboard | Head Assembly* |
|------------------------------|------|-------------------------------------|------------------|---------------|---------------|---------------|---------------|----------------|---------------|----------------|----------------|
| mm | inch | | | | | | | | | | |
| MODEL 10 - 01' SERIES | | | | | | | | | | | |
| 6.35 | 1/4" | DM 60 Series OD Imperial Tube | DLT10PYIG3704 | DLT10PYDI3704 | DLT10MADA0001 | DLT10MAHD0001 | DLT10PSEU4006 | DLT10PYFU704 | DLT10PSEL4006 | DLT10PSFL4006 | DLT10PYHA3704 |

MODEL 40 POWER UNIT - DLT40MAPW0000

| Size | | Fitting Series | Inspection Gauge | Die Set | Die Block | Head | Upper Endplates | Lower Endplates | Endplate Bolts | Head Assembly* |
|------------------------------|------|-------------------------------------|------------------|---------------|---------------|---------------|-----------------|-----------------|---|----------------|
| mm | inch | | | | | | | | | |
| MODEL 40 - 00' SERIES | | | | | | | | | | |
| 9.53 | 3/8" | DM 60 Series OD Imperial Tube | DLT40PYIG3706 | DLT40PYDI3706 | DLT40MADA0000 | DLT40MAHD0000 | DLT40PYEU0000 | DLT40PYEL0000 | MS51595-61 10-24 x 3/8" Flat Socket Cap | DLT40PYHA3706 |
| 12.7 | 1/2" | | DLT40PYIG3708 | DLT40PYDI3708 | | | | | | DLT40PYHA3708 |
| 15.88 | 5/8" | | DLT40PYIG3710 | DLT40PYDI3916 | | | | | | DLT40PYHA3916 |
| MODEL 40 - 02' SERIES | | | | | | | | | | |
| 19.05 | 3/4" | DM 60 Series OD Imperial Tube | DLT40PYIG3712 | DLT40PYDI3712 | DLT40MADA0002 | DLT40MAHD0002 | DLT40PYEU0002 | DLT40PYEL0002 | MS51595-61 10-24 x 3/8" Flat Socket Cap | DLT40PYHA3712 |
| 25.4 | 1" | | DLT40PYIG3716 | DLT40PYDI3716 | | | | | | DLT40PYHA3716 |

MODEL 55 POWER UNIT - DLT55MAPW0000

| Size | | Fitting Series | Inspection Gauge | Die Set | Die Block | Head | Upper Endplates | Lower Endplates | Endplate Bolts | Head Assembly* |
|------------------------------|--------|-------------------------------------|------------------|---------------|---------------|---------------|-----------------|-----------------|---|----------------|
| mm | inch | | | | | | | | | |
| MODEL 55 - 01' SERIES | | | | | | | | | | |
| 25.4 | 1" | DM 60 Series OD Imperial Tube | DLT40PYIG3716 | DLT55PYDI3716 | DLT55MADA0001 | DLT55MAHD0001 | DLT55PYEU0001 | DLT55PYEL0001 | MS51595-61 10-24 x 3/8" Flat Socket Cap | DLT55PYHA3716 |
| 31.75 | 1-1/4" | | DLT55PYIG3720 | DLT55PYDI3720 | | | | | | DLT55PYHA3720 |
| 38.1 | 1-1/2" | | DLT55PYIG3724 | DLT55PYDI3724 | | | | | | DLT55PYHA3724 |
| 50.8 | 2" | | DLT55PYIG3732 | DLT55PYDI3824 | | | | | | DLT55PYHA3824 |

METRIC TUBE – DM 80 / DP 04 SERIES – TOOL PARTS MATRIX (NEW GENERATION TOOL)

*Head Assembly Includes: Die Set, Die Block, Head, Endplates and Endplate Bolts

MODEL 10 POWER UNIT - DLT10MAPW0000

| Size | Fitting Series | Inspection Gauge | Die Set | Die Block | Head | Upper Inboard | Upper Outboard | Lower Inboard | Lower Outboard | Head Assembly* |
|------------------------------|-------------------------------------|------------------|---------------|---------------|---------------|---------------|----------------|---------------|----------------|----------------|
| MODEL 10 - 01' SERIES | | | | | | | | | | |
| 6 mm | DM 80 Series Metric Tube | DLT10PYIG3906 | DLT10PYDI3704 | DLT10MADA0001 | DLT10MAHD0001 | DLT10PSEU4006 | DLT10PYFU704 | DLT10PSEL4006 | DLT10PSFL4006 | DLT10PYHA3704 |
| 8 mm | | DLT10PYIG3908 | DLT10PYDI3908 | | | | | | | DLT10PYHA3908 |

MODEL 40 POWER UNIT - DLT40MAPW0000

| Size | Fitting Series | Inspection Gauge | Die Set | Die Block | Head | Upper Endplates | Lower Endplates | Endplate Bolts | Head Assembly* |
|------------------------------|-------------------------------------|------------------|---------------|---------------|---------------|-----------------|-----------------|---|----------------|
| MODEL 40 - 00' SERIES | | | | | | | | | |
| 10 mm | DM 80 Series Metric Tube | DLT40PYIG3910 | DLT40PYDI3910 | DLT40MADA0000 | DLT40MAHD0000 | DLT40PYEU0000 | DLT40PYEL0000 | MS51595-61 10-24 x 3/8" Flat Socket Cap | DLT40PYHA3910 |
| 12 mm | | DLT40PYIG3912 | DLT40PYDI3912 | | | | | | DLT40PYHA3912 |
| 14 mm | | DLT40PYIG3914 | DLT40PYDI3804 | | | | | | DLT40PYHA3804 |
| 15 mm | | DLT40PYIG3915 | DLT40PYDI3916 | | | | | | DLT40PYHA3916 |
| 16 mm | | DLT40PYIG3916 | DLT40PYDI3916 | | | | | DLT40PYHA3916 | |
| 18 mm | | DLT40PYIG3918 | DLT40PYDI3806 | | | | | DLT40PYHA3806 | |
| 20 mm | | DLT40PYIG3920 | DLT40PYDI3920 | | | | | DLT40PYHA3920 | |
| MODEL 40 - 02' SERIES | | | | | | | | | |
| 22 mm | DM 80 Series Metric Tube | DLT40PYIG3922 | DLT40PYDI3808 | DLT40MADA0002 | DLT40MAHD0002 | DLT40PYEU0002 | DLT40PYEL0002 | MS51595-61 10-24 x 3/8" Flat Socket Cap | DLT40PYHA3808 |
| 25 mm | | DLT40PYIG3925 | DLT40PYDI3925 | | | | | | DLT40PYHA3925 |
| 28 mm | | DLT40PYIG3928 | DLT40PYDI3812 | | | | | | DLT40PYHA3812 |
| 30 mm | | DLT40PYIG3930 | DLT40PYDI3930 | | | | | | DLT40PYHA3930 |

METRIC TUBE – DM 80 / DP 04 SERIES – TOOL PARTS MATRIX (NEW GENERATION TOOL)

*Head Assembly Includes: Die Set, Die Block, Head, Endplates and Endplate Bolts

MODEL 55 POWER UNIT – DLT55MAPW0000

| Size | Fitting Series | Inspection Gauge | Die Set | Die Block | Head | Upper Endplates | Lower Endplates | Endplate Bolts | Head Assembly* |
|------------------------------|--|------------------|---------------|---------------|---------------|--------------------------------|--------------------------------|---|----------------|
| MODEL 55 - 01' SERIES | | | | | | | | | |
| 30 mm | DM 80 Series Metric Tube | DLT40PYIG3930 | DLT55PYDI3930 | DLT55MADA0001 | DLT55MAHD0001 | DLT55PYEU0001 | DLT55PYEL0001 | MS51595-61 10-24 x 3/8" Flat Socket Cap | DLT55PYHA3930 |
| 35 mm | | DLT40PYIG3935 | DLT55PYDI3816 | | | | | | DLT55PYHA3816 |
| 38 mm | | DLT55PYIG3938 | DLT55PYDI3724 | | | | | | DLT55PYHA3724 |
| 42 mm | | DLT55PYIG3942 | DLT55PYDI3820 | | | | | | DLT55PYHA3820 |
| 50 mm | | DLT55PYIG3950 | DLT55PYDI3824 | | | | | | DLT55PYHA3824 |
| 44.5 mm | DP 04 Series Low Pressure Metric Tube | DLT55PYIG4244 | DLT55PYDI3944 | DLT56MADA0001 | DLT55MAHD0001 | DLT55PYEU0001 | DLT55PYEL0001 | MS51595-61 10-24 x 3/8" Flat Socket Cap | DLT55PYHA3944 |
| MODEL 55 - 02' SERIES | | | | | | | | | |
| 57 mm | DP 04 Series Low Pressure Metric Tube | DLT55PYIG4257 | DLT55PYDI3957 | DLT56MADA0002 | DLT55MAHD0002 | DLT55PYFU4032 DLT55PYEU4032 | DLT55PYEL4032 DLT55PYFL4032 | MS51595-61 10-24 x 3/8" Flat Socket Cap | DLT55PYHA3957 |

MODEL 70 POWER UNIT – DLT70MAPW0000

| Size | Fitting Series | Inspection Gauge | Die Set | Die Block | Head | Upper Endplates | Lower Endplates | Endplate Bolts | Head Assembly* |
|------------------------------|-------------------------------------|------------------|---------------|---------------|---------------|-----------------|-----------------|---|----------------|
| MODEL 70 - 01' SERIES | | | | | | | | | |
| 42 mm | DM 80 Series Metric Tube | DLT55PYIG3942 | DLT70PYDI3820 | DLT70MADA0001 | DLT70MAHD0001 | DLT70PYEU0001 | DLT70PYEL0001 | MS51595-61 10-24 x 3/8" Flat Socket Cap | DLT70PYHA3820 |
| 50 mm | | DLT55PYIG3950 | DLT70PYDI3824 | | | | | | DLT70PYHA3824 |
| 60 mm | | DLT70PYIG3960 | DLT70PYDI3832 | | | | | | DLT70PYHA3832 |

Tube-Mac[®] Flaring Tooling



FLARING MACHINE

Part Number: TFM-01-220 (220V/10/50Hz)

Weight: 417 kg

Available for hire or purchase.

Contact Prochem for details.

FLARING PIN

| Part Number | Sizes |
|-------------|---|
| TL-0011A | 1/2" to 1" NB Pipe 6.35 (1/2") to 31.75 mm (1-1/4") OD Tube 12 to 30 mm Metric Tube |
| TL-0012A | 1-1/4" and 1-1/2" NB Pipe 38.1 (1-1/2") to 50.8 mm (2") OD Tube 38 to 50 mm Metric Tube |
| TL-0013A | 2" and 2-1/2" NB Pipe 60 mm and 75 mm Metric Tube |
| TL-0014A | 3" NB Pipe 90 mm Metric Tube |
| TL-0017A | 3-1/2" NB Pipe 100 mm Metric Tube |
| TL-0018A | 4" NB Pipe 115 mm Metric Tube |

METRIC TUBE DIE

| Part Number | Description |
|-------------|-------------|
| PFD-M12 | 12 mm die |
| PFD-M16 | 16 mm die |
| PFD-M20 | 20 mm die |
| PFD-M25 | 25 mm die |
| PFD-M30 | 30 mm die |
| PFD-M38 | 38 mm die |
| PFD-M42 | 42 mm die |
| PFD-M50 | 50 mm die |
| PFD-M60 | 60 mm die |
| PFD-M75 | 75 mm die |
| PFD-M90 | 90 mm die |
| PFD-M100 | 100 mm die |
| PFD-M115 | 115 mm die |

SPARE SHAFT SUPPORT

| Part Number | Description |
|--------------|---------------------|
| 32304 | Inner Shaft Support |
| NJ2305E.TVP2 | Outer Shaft Support |
| TFM01-SK | Spare Seal Kit |

NB PIPE DIE

| Part Number | Description |
|-------------|-------------|
| PFD-050 | 1/2" die |
| PFD-075 | 3/4" die |
| PFD-100 | 1" die |
| PFD-125 | 1-1/4" die |
| PFD-150 | 1-1/2" die |
| PFD-200 | 2" die |
| PFD-250 | 2-1/2" die |
| PFD-300 | 3" die |
| PFD-350 | 3-1/2" die |
| PFD-400 | 4" die |

OD TUBE DIE

| Part Number | Description |
|-------------|-----------------------|
| TFD-050 | 6.35 mm (1/2") die |
| TFD-075 | 19.05 mm (3/4") die |
| TFD-100 | 25.4 mm (1") die |
| TFD-125 | 31.75 mm (1-1/4") die |
| TFD-150 | 38.1 mm (1-1/2") die |
| TFD-200 | 50.8 mm (2") die |